

Developments on Baby Strollers over the Last Decade

ABSTRACT

It has come to an attention that the interest of baby stroller design is still encouraged and popular among worldwide researches and consumers. A visual history and timeline of invented baby strollers since 1973 to today's baby strollers was drafted. Moreover, a ten years review on multiple designs of baby strollers was done ranging from the year 2008 to 2018. Based on the review, there are many possible ways to design a baby stroller which its sole purpose is to transport a baby in a much easier method. Through this review, it is noticeable that baby stroller inventors are implementing addition functions and objectives like rocking mechanism, diaper changing table and others. The use of electronic devices in strollers is slowly implemented as the years increases, although there always potential ideas for improvements. Graphs and tables on baby strollers by their popularity and brand was drawn with online shopping websites as resource to recognize consumer's interest. Besides that, potential improvements and ideas on the design and fabrication of baby strollers were suggested to fit in with the impending society and future generation.

Keywords: Baby stroller; design; fabrication; multi-functional; application; future developments

1. Introduction

The comfort and protection of one's child is every parent's responsibility and a desire to fulfil it. Baby strollers are essential for navigating life with your new baby as it helps to ease the burden of carrying the weight of a baby or toddler on long, or even -short walks. The development of baby stroller throughout the years have improved vastly and significantly, from the form of baby carriages to modern implementations of technology and gadgets. This section of a literature review and research will only be focusing on the designs and applications of baby strollers throughout the many years since it was first invented.

34 The very first baby stroller was invented in the year 1733 by a landscape architect
35 named William Kent as shown in Figure 1. The purpose of this invention was to
36 transport the third Duke of Devonshire’s children alongside to amuse them. Designed
37 in a shell-shape, this carriage had a harness aimed to be pulled by animals like goats,
38 dogs or ponies, with a spring suspension to secure a comfy ride for the baby. Back then,
39 carriages then become a fashionable piece that only the wealthiest parents could afford.



40

41 **Figure 1: First Baby Carriage Invented by William Kent [1]**

42

43 A century later in the mid-1800s, the baby strollers have become an easier
44 navigating transport for babies as the designs substituted handles for parents or nannies
45 to pull the stroller behind her, with the baby facing forward instead of having animals
46 do the pulling as seen in Figure 2. It has been known that pushing is much easier than
47 pulling as it takes a lesser strength and energy from one person. Hence, in 1848, baby
48 stroller came to America and American innovator Charles Burton changed the original
49 design of the carriage, so parents could push their children rather than pulling them.
50 The popular in the United States as inexperienced parents tended to come into contact
51 with pedestrians. However, he managed to patent his designs at England with the name
52 “perambulator”, which we all now know it as pram presented in Figure 3.

53



54

55

Figure 2: Carriage in mid 1800s [2]

56



57

58

Figure 3: The Perambulator invented by Charles Burton [3]

59

60 In today's market, the seat of the baby stroller can be adjusted so that parents or
61 nannies could have the child facing them or facing away from them, whichever they
62 preferred. This improvement was done by African American inventor William H.
63 Richardson as he patented his design in the United States in 1889. Richardson made
64 changes to the carriage wheels allowing it to move independently compared to the
65 previous non-independent wheels as shown in Figure 4. This improvement makes the
66 stroller more manoeuvrable and convenient for parents.

67



Figure 4: Baby carriage invented by Richardson [4]

68

69

70

71 Slowly, the evolution of baby carriages has been improving. Following World War
72 I, the safety features on a baby carriages were introduced and updated [5]. Inventors in
73 1920 made special safety features like bigger wheels, deeper, more spacious, lower and
74 sturdier frames. Having more space, and lower frames can prevent the baby from
75 crawling out or decreasing the distance of the stroller and the ground if the baby were to
76 escape. In the 1930s, materials like plastic and rubber were common materials being
77 used in manufacturing baby stroller while inexpensive chromes are used as an
78 alternative to brass. By the 1950s, baby carriages are a must have for parents as
79 affordable material and safety features are not just a fashion piece but also budget-
80 friendly [6].

81

82 Came the year 1965 when London design engineer Owen Finlay Maclaren
83 invented the first umbrella stroller as seen in Figure 5 after watching his daughter
84 struggled with manoeuvring and travelling with her child and the stroller [7]. Hence, he
85 invented a lightweight and collapsible structures like how an umbrella works as a new
86 generation of baby transport. Maclaren strollers are still in the market to date. In 1984,
87 baby strollers have been made convenient for jogging by replacing the tires to bicycle
88 tires and design of three-wheeled for a steadier frame. These all was reinvented by Phil
89 Baechler after receiving reviews from parents whose jogging is a hobby. Lastly, the last
90 common features we can see in the market today is the double baby stroller developed
91 by the stroller company Baby Jogger in 1986 as presented in Figure 6.

92



93

94

Figure 5: First umbrella stroller invented by Owen Maclaren [8]

95



96

97

Figure 6: Baby Jogger invented by Phil Baechler [9]

98

99 Today's stroller in the market has taken most of the original basic features like
100 ergonomic designs, canopy, rotating wheels, foldable features, rotating seats, and
101 umbrella strollers. The features are not limited to only the ones that have been stated as
102 electrical enhancements such as lights, fans and chair warmers have been incorporated
103 to current baby strollers as well. Figure 7 shows the baby stroller with basic features in
104 the market today.

105



106

107

Figure 7: Baby stroller in market today [10]

108

109 How is a baby stroller, becoming a sophisticated baby transport to cater to the
110 needs of babies in current society? With the current society where everything involves
111 technology and electric components, society looks for an easy way to do things. When
112 the baby feels hot or cold or even irritated, no fan, cushion warmer nor are repellents
113 needed to be carried around. Why? Because everything is made easier with electrical
114 components where it can be installed directly to the baby stroller. Strollers now provide
115 great protection against scorching sun and UV rays as climates are drastically changing
116 from time to time. What society is looking for its durability and a long-term investment.
117 A good quality stroller is usually compliant with the firmest safety standards and is
118 made from strong and durable materials. For example, if parents were to deliver a
119 new-born baby, they will not be required to purchase another stroller as the existing one
120 they had before can be used. This is a long-lasting option and it reduces cost greatly for
121 the adaptation of society today. All in all, parents can feed their baby, entertain them
122 and regulate baby's temperature with just a baby stroller.

123

124

125 There are tons of baby stroller on the market today as we all know it since it has
126 been invented in the 1700s. Although the baby stroller has been here for centuries, it is
127 still a piece that can be creatively improved and a big hit till today. A bar chart as
128 presented in Figure 8 shows the number of articles and reports regarding designs and
129 applications of baby strollers. It can be generated through research to prove that baby

130 strollers until 2018 is still trendy. As an engineer, it is our job to always innovate, invent
131 and design to fulfil objectives and requirements. As shown in the results, baby strollers
132 can still be improved in design and application wise as parents are still interested with
133 it.

134

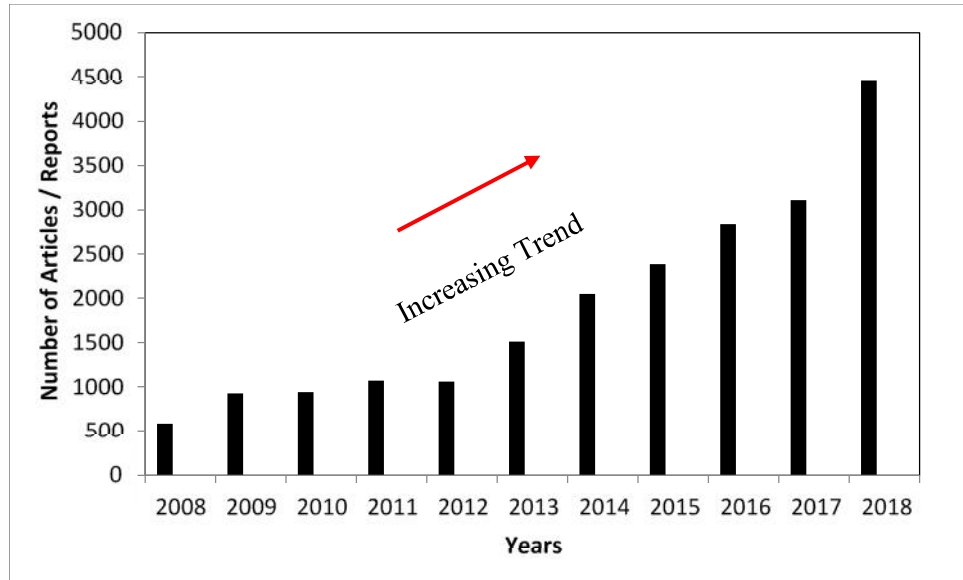

135
136

Source: Google Search Engine Keywords used: baby stroller, designs, application

137

Figure 8: Number of Articles / reports on baby strollers based on designs and applications for year 2008 - 2018

139

140

141 From the above, it can be summarized that the development of baby stroller is still
142 in great interest among worldwide researches and consumers. Hence, this paper intends
143 to dedicate a comprehensive review on the improvement of the design and fabrication
144 or an ergonomic baby stroller from the year 2008 to 2018.

145

146 **2. Patent Reviews**

147 Year 2008

- 148 i) Kun Wang has designed a baby stroller as presented in Figure 9 that includes a
149 first frame, a second frame, and two third frames with front wheels

150 connected to two ends of the first frame by two pivotable members. This
151 baby stroller has various units, for example, folding, operation and
152 adjustment unit. Folding mechanism was applied that can pivot the first
153 frame inward and a rotation member as an operating unit which its job is
154 to fold the handle. Adjustments units are applied for adjusting the seats. This
155 baby stroller comes with a shade frame that is connected to the seat which
156 can be extended or folded.

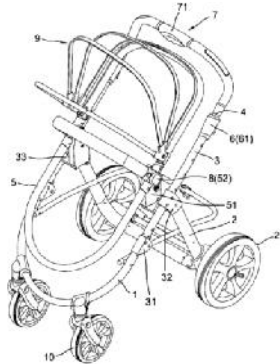

157

158

Figure 9: Baby stroller invented by K. Wang [11].

159

160 ii) In Figure 10, this baby stroller invented by Henry F. Thorne, Robert Daley,
161 and Mary Koes have one or more components which are automatically and
162 easily movable by a drive mechanism between an operative position for the
163 stroller usage. It can be in a collapsed position for more storage and
164 transportation. This baby stroller has an easy folding mechanism where the
165 wheels can be tucked in [12–14].



166

167

Figure 10: Baby stroller invented by Thorne, Daley and Koes [12].

168

169 iii) The child seat is positioned on the stroller frame as shown in Figure 11. This
170 baby stroller was invented by Robert Pike, Todd Sorzano, Gregory Sellers
171 and Dmitriy Faktorovich. The stroller includes a child barrier that includes a
172 cup holder horizontally. When the child barrier moves relative to the stroller
173 frame, the cup holder pivots horizontally. The user can store their
174 beverage as well as the baby's beverage instead of holding in their
175 hand[15–22].



176

177 **Figure 11: Baby stroller invented by Pike, Sorzano, Sellers and Faktorovich [23].**

178

179 Year 2009

180 i) Baby stroller in Figure 12 was invented by Gerjan Storm. It is a rather
181 simple design for a stroller frame, but it serves its purpose as baby transport
182 system. It consists of three wheels with a baby seat attached in the middle.
183 The seat is attached at the centre of gravity of this baby stroller for better
184 stability.



185

186 **Figure 12: Baby stroller invented by Storm [24].**

187

188 ii) A deployable side seat for a baby stroller as seen in Figure 13 was invented
189 by Marie Schutzendorf and Corbett Griffith. An optional removable side
190 seat for a baby stroller, to seat a second child is secured by hand-operated
191 connectors to nearly any baby or child stroller without using tools. The side
192 as can see, it faces to the side to the stroller and has a deployed position in
193 which two wheels are fixed in tandem on the side seat frame contact the
194 pavement. The side seat can be folded neatly and compactly when not in
195 use[25–27].



196

197 **Figure 13: Baby stroller invented by Schutzendorf and Griffith [25].**

198

199 iii) This rather interesting baby stroller design as shown in Figure 14 was
200 invented by Martin Troup and Groner Troup. This baby stroller was made
201 with the intention to allow the child to seat, stand or in reclined position.
202 Moreover, it is fully collapsible. The stroller has opposing side walls, a
203 front wall, a seat and a floor member suspended below the seat. This stroller
204 is supported by four wheels, has a canopy, a standing space formed between
205 a front edge of the seat base and the handrail to allow the child sufficient
206 room for standing while holding the handrail [28–30].



207

208

Figure 14: Baby stroller invented by Troup[28].

209

210 Year 2010

- 211 i) Inventor Jian-Qun Li designed a tandem stroller as in Figure 15. The
212 objective of this invention is to provide a tandem stroller that has a
213 shortened length in a front -to-rear direction. The front seat includes a front
214 seat plate disposed on the frame that can place beverages on it.
215 Consequently, the total length of the stroller in a front to rear direction is
216 shortened significantly[31,32].



217

218

Figure 15: Baby stroller invented by Li [31].

219

- 220 ii) Figure 16 shows a stroller that includes a frame having at least one front leg,
221 one rear leg and at least one wheel mounted on each leg. The inventors are

222 Jeff Greger and Michael Longnecker. The stroller includes a seat having a
223 seat base and a seat back pivotally mounted to the frame. The frame for the
224 baby seat is rather low and spacious to support the size of the travel
225 attachment[33–35].

226

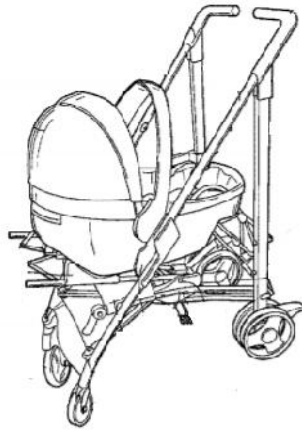

227

228 **Figure 16: Baby stroller invented by Greger and Longnecker[33].**

229

230 iii) Inventors Wes Thomas, Toriono Granger and James Morrow invented baby
231 stroller in Figure 17 with the purpose of having the child to seat or stand on
232 this two in one stroller. The stroller includes a frame and a seat having a
233 seat pan that is pivotable between a raised and lowered position. In the
234 lowered position, the seat pan is to support the child in a seating position.
235 The standing position is allowed due to the foot platform coupled to the
236 frame[36].



237

238 **Figure 17: Baby stroller invented by Thomas, Granger and Morrow[36].**

239

240 Year 2011

241 i) Gerald Gross has designed an illuminable baby stroller having embedded
242 light sources as shown in Figure 18 which can control the lights. LEDs are
243 preferably used as light sources embedded in the frame of the stroller in
244 translucent sections of the frames making the stroller visible in dim and dark
245 lighting. This stroller includes a forward and rear light source that
246 illuminates the path in front and the back of the stroller[37–41].

247

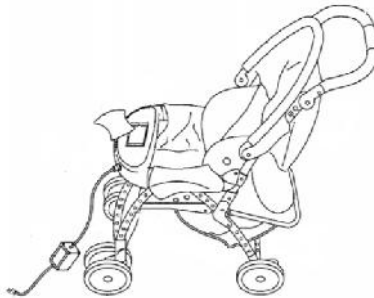

248

249 **Figure 18: Baby stroller invented by Gross [37].**

250

251 ii) The objective of this invention of baby stroller as shown in Figure 19 is to
252 overcome the shortcomings of the conventional stroller that has a handle bar
253 that is not adjustable and a bulky shape that is difficult for storage. Chin-I
254 Lai the inventor improved the shortcomings by including a handle set
255 containing an elevation set and a folding set. The elevation serves its
256 purpose by allowing adjustments to the length while the folding set allows
257 the baby stroller to shrink into a smaller size when folding[42–44].



258

259

Figure 19: Baby stroller invented by Lai [42].

260

261 Year 2012

- 262 i) This combined shopping trolley baby stroller in Figure 20 was designed by
263 Harri Ektron. This baby stroller/cart includes a four-wheeled cross-shaped
264 frame that carries a box-shaped basket and a child seat. The basket can be
265 changed to half volume and thus can form a child's seat used in the front
266 seat of cart. The baby stroller seat can be removed to form a full shopping
267 car to be used[45–49].

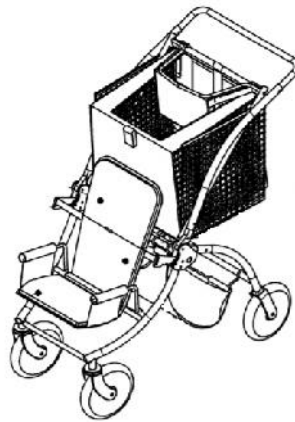

268

269

Figure 20: Baby stroller invented by Ektron [45].

270

- 271 ii) Figure 21 represents a stroller designed for people with interest in sports.
272 The baby stroller was designed by Jean-Pierre Joubert with the idea of
273 having an athletic accessory container built into the baby stroller. The baby

274 stroller includes a frame having a front-forward facing seat for infants to be
275 seated. An enclosure area is defined by a cross-member that spans the
276 spaced apart frame members. An athletic container is carried on the support
277 and extends through the enclosure area[50–53].



278

279 **Figure 21: Baby stroller invented by Joubert [50].**

280

281 iii) Baby stroller presented in Figure 22 is an automatically controllable smart
282 stroller invented by Chih-Hsiung Yang. This baby stroller includes a frame,
283 a body-movement detecting unit provided on the frame, a drive control unit
284 and a drive unit. The drive control unit electrically connects with the body
285 movement detecting unit and drive unit. The objective of this baby stroller is
286 to provide an automatically smart stroller with a synchronous drive
287 mechanism[54–58].



288

289 **Figure 22: Baby stroller invented by Yang [54].**

290 Year 2013

291 i) This baby stroller in Figure 23 was designed by Mark Zehfuss and Gordon
292 Liao and was inspired to form a baby stroller with a stroller frame and a
293 chair. The stroller frame has a rotatable base and the chair includes a folding
294 joint such that the chair can be folded directly onto the stroller frame to
295 provide a simple and easy quick operation to accomplish the effect of
296 reducing the storage volume of a baby stroller. The chair may be mounted
297 facing forward or rearward [59–62].

298



299

300 **Figure 23: Baby stroller invented by Zehfuss and Liao [59].**

301

302 ii) The present invention as shown in Figure 24 was invented by Cheng-Fan
303 Yang, Chen-Tai Chang, Sheng-Po Hung and Fu-Peng Chou. This baby
304 stroller can be extended horizontally and tucked back in. It is a convertible
305 tandem stroller frame, especially to a convertible tandem stroller frame
306 equipped with a release actuator mounted at the front end of it lock and
307 un-lock a longitudinal telescopic mechanism[63–67].

308



309 **Figure 24: Baby stroller invented by Yang, Chang, Hung and Chou [63].**

310

311 Year 2014

312 i) A rather unique baby stroller as shown in Figure 25 was designed by
313 Bradley James Mattarocci where it includes a platform that the child can
314 stand on. This stroller consists of a frame, a plurality of wheels supporting
315 the frame, a forward and rearward facing seat supported by the frame, seat
316 back and platform positioned rearward of the forward-facing seat. The seat
317 back helps to support the back if the child seated in the rearward facing seat
318 in the rearward direction. In addition, the seat is moveable between a use
319 and storage position to increase child's access to stand on the platform
320 [68–71].

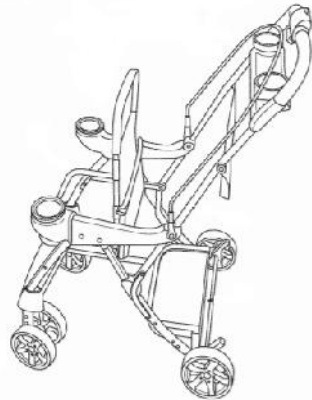

321

322 **Figure 25: Baby stroller invented by Mattarocci [68].**

323

324 ii) Baby stroller presented in Figure 26 has a sole purpose of enhancing the
325 safety of baby strollers by implementing a safety device that prevents
326 runaway baby stroller. This baby stroller is very useful especially on rainy
327 days as sidewalks can be slippery and pose a threat on the stroller wheels if
328 person pushing the stroller stops and doesn't apply brakes. Baby stroller
329 designed by Leonard Storch has improved the baby stroller by providing
330 fully automatic slip-clutch joining means to inhibit veering off by
331 automatically coupling the stroller's rear wheels together when the stroller
332 is stopped. Once it has been coupled, the rear wheels must rotate in unison

333 thus helping to prevent the stroller from veering off towards the curb. The
334 slip clutch disengages when the stroller is being pushed [72–74].

335



336

337 **Figure 26: Baby stroller invented by Storch [72].**

338

339 iii) Baby stroller in Figure 27 was designed with a purpose for better storage.
340 Ryan Hawker and David N Foster are the inventors behind this baby stroller
341 design. The seat-frame assembly can be rearranged at the option of the user
342 to change from expanded use mode to a relatively narrowed collapsed
343 storage mode [75–78].

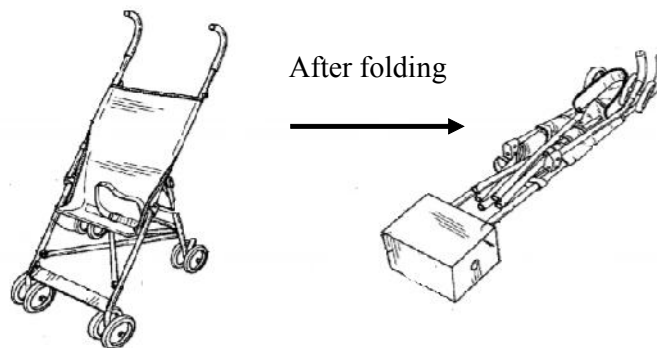

344

345 **Figure 27: Baby stroller invented by Hawker and Foster [75].**

346 Year 2015

347 i) Figure 28 shows a baby stroller invented by Sean Gilbert that incorporates a
348 lighting system to the stroller. The lighting system can be found underside
349 of the stroller, comprising a fasten able light strip. A wiring harness

350 fasten able to the frame of the stroller that is wire configured to electrically
351 connect the light strip to the power supply. This baby stroller has a switch
352 integrated to it to activate and deactivate the light strip whereby, when the it
353 is on active mode, the ground beneath the baby stroller is illuminated.



354

355

Figure 28: Baby stroller invented by Gilbert [79].

356

357 ii) This baby stroller presented in Figure 29 is a portable, foldable,
358 baby-changing table unit is provided attachable to a baby stroller. It is
359 invented by Daniel and Magdalini Penello. This unit includes connectors for
360 connecting the baby-changing table unit to the stroller's baby car seat
361 connectors. A flexible changing pad to be attached to the portable
362 baby-changing table unit includes a diaper receiver and a handy-wipe
363 receiver [80–84].



364

365

Figure 29: Baby stroller invented by Penello [80].

366

367 iii) Baby stroller in Figure 30 is a convertible jogger and all-terrain stroller
368 invented by P. Leys, Santos, Hei, E.Bartz, Dudkowski, Maddox, and
369 C.Wang. This stroller can be used in two modes which are for jogging and
370 another for everyday use. The seat base is operable to suit the stated modes.
371 The everyday mode has a relatively short base and high profile while for the
372 jogging mode have a long base and low profile. The baby stroller includes
373 3 wheels, one at the front and two at the rear [85–87].



374

375 **Figure 30: Baby stroller invented by Leys, Santos, Hei, E.Bartz, Dudkowski,**
376 **Maddox, and C.Wang [85].**

377

378

379

380 Year 2016

381 i) This baby stroller in Figure 31 was designed by Tsoung-Yong Liao and he
382 has invented this with an expanded or folded mode. The sole purpose of this
383 invention is to minimize storage space and for easier transportation by
384 reducing the slide block and the couplings between components. This baby
385 stroller is folded part by part to get a flat square like shape in the end. This
386 stroller is packed with a lower frame, a slide block, a pull rod set, a rear
387 wheel link rod and frame, first and second handle rod set, and a front wheel
388 frame [88–91].

389



390

391 **Figure 31: Baby stroller invented by Liao [88].**

392

393 ii) Provided in Figure 32 below, this baby stroller special function is its folding
394 mechanism that allows occupies less space, improve its portability facilitate
395 its storage and transportation. This stroller is built upon couplings between
396 the slide block and rear wheel rocker arms, the handling tube, an upper
397 frame that assist in this expanded and folded mode. Tsoung-Yong Liao from
398 Tainan is the man behind this invention [92–94].

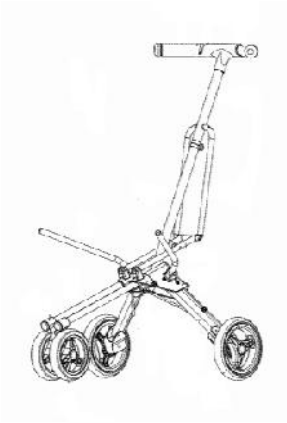

399

400

Figure 32: Baby stroller invented by Liao [92].

401

402 iii) The baby stroller in Figure 33 is a stroller with telescopic and locking
 403 members invented by Patrick Laffan, Leslie Stiba, and Hao Tian. A stroller
 404 comprising and additional storage area or child support system when
 405 expanded. The frames include a mechanism whereby the base of the frame
 406 is expanded backwards to create more storage space behind the baby seat.
 407 The stroller may include detachable wheels and handles or push bars that
 408 can assist in expanding and contracting the storage area [95–98].



409

410

Figure 33: Baby stroller invented by Laffan, Stiba and Tian [95].

411

412 Year 2017

413 i) Corban Perry invented a motorized baby stroller as shown in Figure.34 A
 414 motorized baby stroller for transporting a baby may include a front section,
 415 a side section connected to the front and back section. The front section

416 includes a cavity to hold the baby and includes a proximity detector to detect
417 a baby in the cavity and control the motors. It has a control panel that might
418 include a switch and a battery meter.

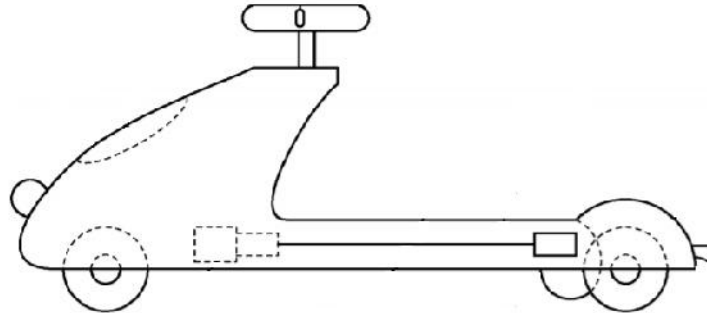

419

420 **Figure 34: Baby stroller invented by Perry [99].**

421

422 ii) Susan Gopaul invented baby stroller shown in Figure 35 with basic features
423 yet multifunctional. The seat can be facing in a downward or sleeping
424 position for the child. It can be placed so that the baby can see the front view
425 or the be seated to see the rear view[100].



426

427 **Figure 35: Baby stroller invented by Gopaul [100].**

428

429 iii) This collapsible baby carriage as shown in Figure 36 was invented by Qiang
430 Zhang. It includes a pair of middle pushing rod, a pair of upper pushing rod,
431 a pair of T-rod, a pair of front wheel rod, a pair of bending-extension rod, a
432 pair of side sliding rod, a pair of handles and a pair of seat side bending rod
433 at two sides thereof. The baby carriage includes a folding mechanism. The

434 folding mechanism turns the upper pushing rod upward and the middle
435 pushing rod and the front wheel rod downward. The flipping mechanism
436 flips the seat side bending rods, the bending-extension rods, the front wheel
437 rods, the front wheels, the handles, the T- rods and the rear wheels inward,
438 forming a flat and rectangular body [101–105].
439

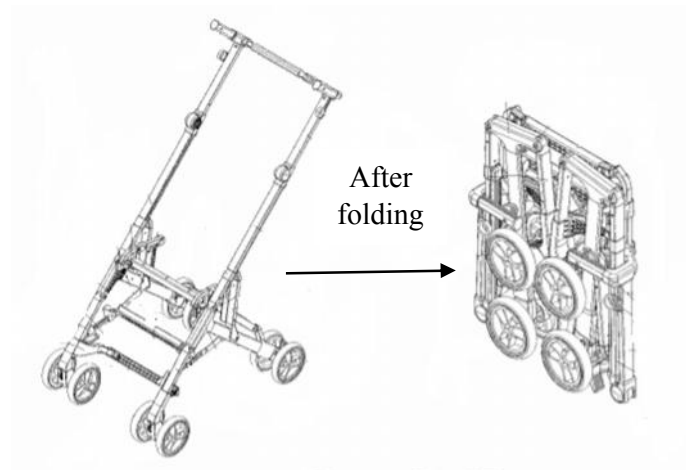

440
441
442

Figure 36: Baby stroller invented by Qiang Zhang [101].

443 Year 2018

444
445
446
447
448
449
450
451
452
453
454

- i) Child stroller in Figure 37 was invented by Kori Faith Duboff and Kimberly Mar Alicea. It includes a frame, a plurality of wheels, a child-seat assembly configured to rock back-and-forth with respect to the frame; a rocker assembly secured to the child-seat assembly. The rocker assembly includes a plurality of legs, each leg defining an undersurface, each undersurface being arced a rocker base, the rocker base comprises an inner surface. The stroller is configured such that when the child-seat assembly rocks back-and-forth with respect to the frame, the legs rock back-and-forth upon the inner surface of the rocker base[106].



Figure 37: Baby stroller invented by Qiang Zhang [106].

455

456

457

458

459

- ii) This convertible baby stroller in Figure 38 was invented by Christy Hanson, Robert R. Roberts, Sienkiewicz, Travis Yoch, and Peter Young. A design that is rather unique because this baby stroller can be worn around the user's waist with a pulling rail that can attach to an adjustable running belt. An adjustable stroller having a main carriage and a handle bar assembly that is configured to allow the user to push or pull the stroller. A third front wheel is built for stability and balance reciprocating the two rear wheels attached to the main carriage. Furthermore, the adjustable stroller more specifically includes main carriage, pulling rails comprised of handle bar tubes and telescoping rail tubes, three wheels, a crossbar and a centre handle [107–110].

460

461

462

463

464

465

466

467

468

469

470

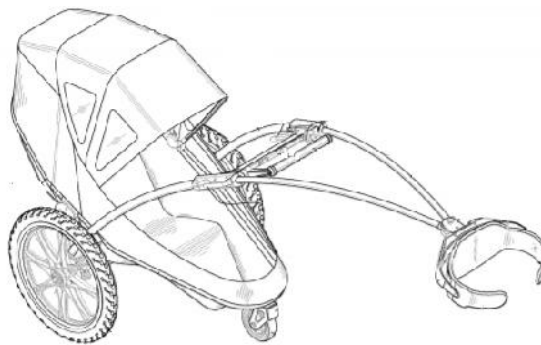

471

472

473

Figure 38: Baby stroller invented by Hanson, Roberts, Sienkiewicz, Yoch, and Young [107].

474 iii) Baby stroller in Figure 39 was invented by Manuel Abreu with the intention
475 to control the temperature of the baby stroller from hot and cold weathers.
476 This stroller is built with a frame, a seat on the frame for the child and a
477 temperature controllable element which is adjacent to the seat. The
478 temperature controllable element controls the temperature of an
479 environment of the child. It provides plenty storage at the bottom of the
480 stroller. The heating and cooling element is a continuous hollow tube for
481 transferring air, liquid or gas [111].

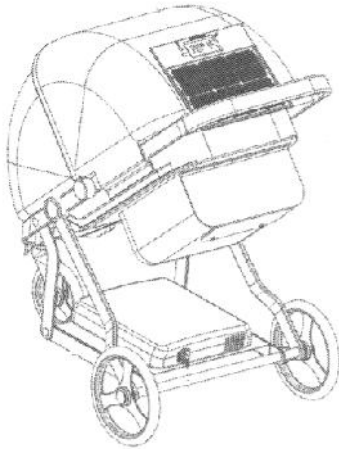

482

483

Figure 39: Baby stroller invented by Abreu [111].

484 **3. Summary of patent review**

485 From the patent review of the year 2008 to 2018, there are a few characteristics and
486 points that can be concluded on the design of baby strollers throughout these years.
487 These are the following basic features and mechanism can be seen on baby strollers.
488 The features are canopy or shades for providing shade, foldable mechanism for proper
489 and easy storage, ergonomic designs, and comfortable baby seats suitable for
490 new-borns or toddlers and ample storage space[112]. These are the basic features that
491 should have in a basic baby stroller to ease users when transporting a baby.

492 Next, improvements and innovative ideas can be seen in the designs of baby
493 strollers as the year's increases. Firstly, electrical components such as lights operated
494 by dynamo, battery or electrically wired are implemented. Furthermore, different
495 countries have a different climate where some places are either too hot or too cold. To
496 overcome this, temperature controllable elements are newly introduced. From the
497 patent review, we can see many kinds of designs newly introduced which are more
498 modern and unique as the year increases. Moreover, one of the baby stroller designs
499 from patent year 2009 and 2014 allows the child to stand on the baby stroller.
500 Implementation of multipurpose baby stroller, for example, baby-changing table unit,
501 attachable to shopping carts and extra seating can be seen in the modern baby stroller.
502 Throughout the years since baby strollers were designed, it is noticeable that modern
503 baby strollers are advancing technologically and can be operated by motor.

504

505 **4. Survey on preferred strollers in Malaysia**

506 Baby stroller has all the basic features that parents know of as stated in the section
507 above. It can be summarized that the preferred baby strollers have characteristics like
508 lightweight, multi-functional, ample storage, cup holders, safety features and
509 importantly features that prioritized their child's comfort. A further research has been
510 done as shown in Table 1 that focuses on baby stroller customers in Malaysia. This
511 particular research is done to understand and learn in depth of parents' choice and
512 preference on baby stroller. The source of research will be based on online shopping
513 websites that are visited frequently by Malaysian customers.

514

515 Table 1 as shown below is based on its popularity by customers in online shopping
516 websites targeted in Malaysia. The baby stroller popularity is rated according to the
517 number of stars, five stars being the highest. According to research, parents prefer
518 strollers that have safety features, easy to store it anywhere, storage, canopy availability,
519 and new-born ready. This can be proven by referencing to Table, as the baby strollers
520 that are popular in online shopping websites fulfilled said criteria. This helps us to
521 know what the focusing points when inventing or applying innovations to baby strollers.
522 A few baby strollers, for example, baby stroller brand Sweet Heart Paris ST230 serves a
523 multi-functional purpose, such as it can be used as a rocking chair. As the generation is
524 evolving, new innovations and technological mechanism can be introduced to attract
525 parents and baby stroller users.

UNDER PEER REVIEW

526 **Table 1: Popular baby strollers in online shopping website, Lazada and Shopee.**

Brand	Rating (1-5 stars)	Features
 OSH 5 Wheels Magic Stroller	55	Foldable, adjustable aluminium alloy, regulating pedal, comfortable seat, Weight: 3.2kg
 GB Pockit Plus	5	Smart and ultra-compact folding, 5-position harness system, adjustable seatback, storage and canopy availability, self-standing when folded, one-hand push, Weight: 5.6kg
 Joie Pact Cabin	5	Compact fold, full-size canopy with eyeshade visor, UPF 50+ sun canopy, multi-position recline for backrest, full-size storage, 5-point harness, wheel suspensions, Weight: 6kg

527

528

Remark: 1 star implies least popular; 5 stars implies most popular

529

Source: Online shopping platform- LAZADA website; Shopee website; Keywords used: baby strollers, designs, popular

530

531
532

Table 1 (cond't): Popular baby strollers in online shopping website, Lazada and Shopee.

Brand	Rating (1-5 stars)	Features
 Little One 2 in 1	5	Foldable, tray with cup holder, large storage, additional baby car seat, one-hand folding system, lockable front swivel wheel, reclining seat, canopy availability with window, 5-point harness
 AMGO Detachable T1508	5	Foldable, shock absorption system, multiple reclining positions, canopy and storage availability, sun-proof fabric, top grade single-foot brake system, adjustable handle height, non-slip grip, 5-point harness
 Sweet Heart Paris ST230	4	Foldable, rocking mechanism, three-position backrest adjustments, washable and comfortable seat, adjustable handle, brakes availability, 3-tier canopy with mosquito net, Weight: 7.3kg
 ECOBEE	4	Foldable, multiple position seat recline, 5-point safety harness, lockable front swivel wheels, rear wheel suspensions, storage and all-weather adjustable canopy availability, brake availability, ultra-light, Weight: 3.8kg

533
534
535
536

Remark: 1 star implies least popular; 5 stars implies most popular

Source: Online shopping platform- LAZADA website; Shopee website; Keywords used: baby strollers, designs, popular

537 Next, research has been done to recognize what are the popular baby stroller brands
538 in our targeted location, Malaysia. As a buyer, a recommended brand is always
539 reassuring because users will know if it's the right or close to the perfect choice for
540 other users. Good brands that are highly recommended should be able to fulfil parent's
541 needs in everything they hoped for in a baby stroller.

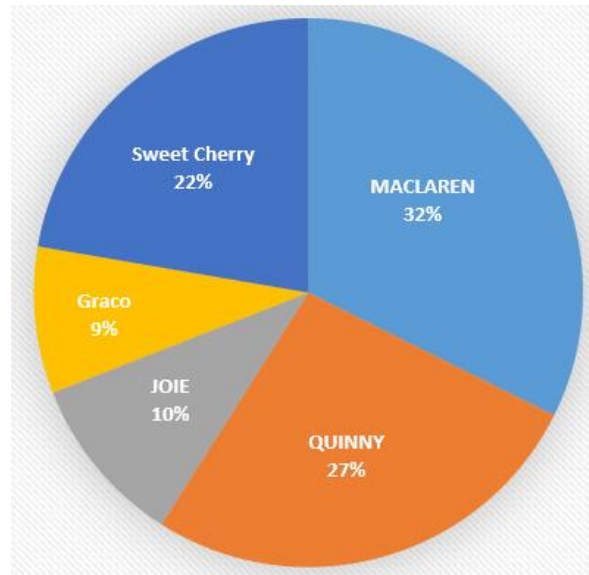

542
543 *Source: Google Search Engine Keywords used: baby stroller, recommended, popular, Malaysia*

544 **Figure 40: Popular baby stroller brands in Malaysia.**

545
546 Chart presented in Figure 40 are the few shortlisted brands that are popular in
547 Malaysia. These trendy and highly recommended brands lean a little towards the pricier
548 cost compared to the baby strollers on online shopping websites such as Shopee and
549 Lazada. Nevertheless, of its price, it is still a popular choice among users in Malaysia.
550 These baby stroller brands are referenced from various shopping websites where baby
551 stroller can be purchased according to its brands. Top in the recommended list would be
552 baby stroller brand Maclaren as it is the most suggested brands in Malaysia[113].
553 Maclaren was founded since 1967 and it's still a popular choice due to their variety of
554 baby stroller selections. Maclaren products are customized for a variety of lifestyles,
555 fashions, trends, and are proud of their safety and durability of baby strollers. Quinny is
556 another brand to look forward to as it is a rather popular choice of baby stroller users.
557 Quinny offers a variety of baby strollers that also serve multipurpose functions with its
558 accessories. Other brands like Sweet Cherry, Joie and Graco as mentioned in the chart

559 are also top choices among Malaysian users. Ergonomic designs and functions are the
560 primary implications in these baby stroller brands.

561 To summarize this section, baby strollers with easy to like designs that must have
562 basic features like canopy, storage, safety features and multipurpose functions are the
563 most common choice among users. When inventing or making improvements, these
564 baby stroller features must be taken into considerations to create an ergonomic baby
565 stroller. In addition, since technical features and trendy items are still less implemented,
566 it is recommended to consider such features to be added into baby stroller designs and
567 applications.

568

569 **5. Future Research**

570 Baby stroller design is still a topic of interest, and as an engineer, it is in our
571 profession to look for ways to improve and innovate. There are still functions and
572 potential ways to improve the design of existing baby strollers.

573 Baby stroller wheels are the base that maintains the stability of its chassis. An idea
574 to combine present invention that are rather popular among generation today may be
575 implemented. This invention can be served as wheels for the baby stroller and later be
576 detached to be functioned as another purpose[68][114]. Safety features are needed as
577 the wheels are crucial parts of the baby stroller. An easy locking system that can be
578 controlled with a single part of the body to cater users especially ones with backache
579 issues and usually pregnant ladies. Wheels that are not too tight yet safe to be
580 manoeuvred with one hand, so users can multitask with the other hand. For tyres, shock
581 absorber makes the bumpy ride to a smooth sailing and reduces vibrations acting on the
582 baby and a user's hands.

583 Baby stroller users are usually in different heights. An adjustable height
584 mechanism that users are familiar with, for example, mechanism that can be seen on
585 suitcases are to be implemented. Two kinds of handles may be enforced to ensure ease
586 to users when they are given a situation where either one hand or two hands are to be on
587 the baby stroller. Baby strollers should also be favourable for users. As seen in existing
588 strollers, cup holders serve a good purpose. So, there will be improvements done on
589 these cup holders.

590 The canopy is essential on baby strollers as they serve multiple purpose. Living in a
591 tropical country, mosquitoes are very threatening. Existing baby strollers provide
592 mosquito nets, but it is needed to be carried separately. The idea to combine the net to
593 prevent from having the trouble to carry it separately or ends up forgetting to bring the
594 mosquito net. A better viewing area can be done so that baby stroller users could look
595 from behind at their child while pushing the stroller.

596 Fabrics to be used may be baby proof friendly to lessen the hassle of having to
597 clean and washing it up frequently. It can be cooling and non-heat absorbent for the
598 comfort of the baby and the user. Material for baby stroller handles may be heat
599 resistant and capable of absorbing moisture, sweat and provides good gripping for the
600 user.

601 Existing baby strollers have some lacking on electrically operated and necessary
602 features. Multiple attachments can be implemented on baby strollers for fulfilling an
603 ergonomic design and serve many positive purposes. Improvements can be made to
604 these attachments, for example, adding more kind of attachments and having
605 everything fixed in one solid attachment. The attachments should serve good and legit
606 functions for the baby and the user. The new potential attachments can cater to the
607 needs of babies by making them comfortable on hot weathers and allow the users to
608 navigate baby strollers in a poor lighting area. Attachments may also entertain the baby
609 much easier[115][37].

610 The seat is another crucial part of a baby stroller. There are many potential
611 possibilities to improve the seat and seating area for the baby's comfort. The seats may
612 be well ventilated and heated as per user's request for baby's convenience. Extra
613 spacious compartments may be added in this area and the design of the baby seat should
614 be able to support the baby's backbone. The seat may also have multiple positions that
615 can be adjusted and incorporate the element of attachability for further purpose[112].

616 Safety features of this improved baby stroller shall meet parents' satisfactions.
617 Shielding will be an important element in this category. Extra cushioning is necessary
618 to protect the baby or child's fragile figure. Five-point harness system will be used
619 because that is the best safety belts to prevent babies from falling or tripping. A
620 mechanical device may be added to prevent bumpy rides and reduce vibrations acting
621 on the baby and a user's hands.

622 It is important to know that there is always room for improvements and right ideas
623 to achieve a new purpose of an invention. With the world moving forward to an era of
624 smart technology, we are bound to succumb to future needs. Future inventions should
625 be able to fit in with the impending society and generation. Thus, there are always
626 potential ways to modify existing inventions to accord for the future.



627
628

629 **Figure 41: Proposed attachments on baby stroller for various application.**

630

631 The proposed attachments as presented in Figure 41 are a few of the attachments
632 that are essential to a baby stroller. These attachments will benefit both the baby and
633 user as it serves a practical purpose. The idea of combining four attachments into one
634 whole attachment can be considered and implemented. By doing this, baby stroller
635 users would not need to carry multiple attachments when they are in need of it. The
636 attachments are modern and popular items used by society today especially the use of
637 hover board.

638 **References**

- 639 [1] Devonshire, First Baby Carriage, (2006).
- 640 [2] A. Martin, Mid 1800s baby stroller, (1800).
- 641 [3] C. Burton, Perambulator, (1848).
- 642 [4] phil&teds, Baby Stroller by William H.Richardson, (2017).
- 643 [5] Whattoexpect, History of Baby Stroller, (2017).
- 644 [6] Whattoexpect, MASS-PRODUCED STROLLERS, (2017).
- 645 [7] M. Bellis, History of Baby Carriage, (2017).
- 646 [8] Maclaren, First Umbrella Stroller, (1967).
- 647 [9] Baby Jogger, Baby Jogger, (1984).
- 648 [10] Mon Ami, Baby stroller in market, (2018).
- 649 [11] K. Wang, Foldable Baby Stroller, 2008.
- 650 [12] H.F.T.D.D.J. Koes, Stroller, US 20080211206A1, 2008.
- 651 [13] A. Wegner, Collapsible pram/pushchair frame, 1993.
- 652 [14] J. Feyler, Children's carriage having a backrest that can be pivoted by an electric
653 motor, 2003.
- 654 [15] L. Habib, Basket for stroller, US4346912A, 1979.
- 655 [16] K. Kassai, Seat assembly for baby carriages, US4435012A, 1981.
- 656 [17] A. Evron, Infants' carriages, US4491335A, 1982.
- 657 [18] K. Kassai, Baby carriage, US4610460A, 1984.
- 658 [19] K. Kassai, Mechanism for locking the opened state of a baby carriage,
659 US4542916A, 1983.
- 660 [20] K. Kassai, Baby carriage, US4626030A, 1985.
- 661 [21] K. Kassai, Baby carriage, US4317581A, 1980.
- 662 [22] K. Kassai, Mechanism for locking opened state of baby carriage, US4616844A,
663 1984.
- 664 [23] R.T.P.D.S.S.S. Faktorovich, Stroller with child barrier and pivotable cup holder,
665 US007571925B2, 2008.
- 666 [24] G. Storm, Stroller, USD615461S1, 2009.
- 667 [25] M.S. Griffith, Deployable side seat for a baby stroller, US8128103B1, 2009.
- 668 [26] L.G. Hobgood, Supplementary seat for motor-cycles, US1212221A, 1917.
- 669 [27] P.C. Hicks, Seating and controlling attachments for barber chairs, US2836224A,
670 1954.

- 671 [28] P.M.T.G. Troup, Infant stroller, US20110095510A1, 2010.
- 672 [29] R. Cletus, Tandem two-seat stroller, US3309101A, 1965.
- 673 [30] S.-M.C.-R. ZHONG, Collapsible stroller, US20080238042A1, 2008.
- 674 [31] J.-Q. Li, Tandem stroller, US8602441B2, 2010.
- 675 [32] Iiik.J.W. Charles E. Wheeler, Carriage assembly, US4542915A, 1983.
- 676 [33] J.G. Longenecker, Stroller with travel seat attachment, US20100171289A1,
677 2010.
- 678 [34] F. Reginald, Automatic brake mechanism for hand-propelled vehicles,
679 US1709527A, 1927.
- 680 [35] H.W.S.T. Baumgartner, Collapsible stroller, US2783053A, 1956.
- 681 [36] W.T.G. Morrow, Sit or stand strollers and methods of making the same,
682 US20100244393A1, 2010.
- 683 [37] G. Gross, Illuminable baby stroller, US20120155097A1, 2011.
- 684 [38] R.P. Stauffer, Stroller with programmable information module,
685 US20030132612A1, 2003.
- 686 [39] F.Y.F.M.P. Dodman, Intrinsically illuminated tubular member of a bicycle and
687 bicycle having same, US20120051072A1, 2011.
- 688 [40] S. Gilbert, Baby stroller lighting system, US 2016.0009219A1, 2015.
- 689 [41] J.A. Thomas, Illuminated Rigid Body Using Contiguously Illuminated Light
690 Source, US20080266833A1, 2008.
- 691 [42] C.-I. Lai, Baby carriage, US20120292888A1, 2011.
- 692 [43] K. Kassai, Baby carriage, US4191397A, 1978.
- 693 [44] K. Kassai, Collapsible baby carriage, US4272100A, 1979.
- 694 [45] H. Ektron, Combined shopping trolley baby stroller, US20140232088A1, 2012.
- 695 [46] S.G. Brottman, Shopping cart, US2615726A, 1947.
- 696 [47] J.R.S. Michels, Stroller convertible to walker and carriage, US3079162A, 1961.
- 697 [48] L.G. Bell, Foldable cart, US4765644A, 1987.
- 698 [49] L. Stiba, Stroller and shopping cart, US8070180B2, 2008.
- 699 [50] J.-P. Joubert, Infant stroller with athletic accessory container,
700 US20120319371A1, 2012.
- 701 [51] H.O. England, Golf carts, US3291502A, 1966.
- 702 [52] H.A. John, Golf club carrier in the form of a trolley, US3360279A, 1967.
- 703 [53] J.K. Fontenot, Combined golf bag and cooler cart, US5193842A, 1992.
- 704 [54] C.-H. Yang, Automatically Controllable Smart Stroller or Wheelchair,
705 US20130162396A1, 2012.

706 [55] G.J. Felling, Chaise lounge with motor-driven adjustable canopy, US5069504A,
707 1990.

708 [56] H. Richmond, Vehicular security system with remote signalling for auto
709 carjacking functions, US5382948A, 1993.

710 [57] P.Z.A. Nyberg, Wheelchair power system, US5495904A, 1994.

711 [58] D.K.L.M. Lim, Wheelchair control sensor using movement of shoulders and
712 wheelchair drive control apparatus using the same, US20040216943A1, 2003.

713 [59] M. Zehfuss, Baby stroller, US20130113185A1, 2012.

714 [60] K. Kassai, Baby carriage, US4846494A, 1988.

715 [61] S.A.S. von Flotow, Collapsible baby stroller and releasable locking and folding
716 mechanism therefor, US6102431A, 1998.

717 [62] R. Glover, Stroller latch apparatus, US6422586B1, 1999.

718 [63] C.-F.Y.-T.C.-P.H.-P. Chou, Convertible tandem stroller frame,
719 US20130234419A1, 2013.

720 [64] D.M. Gondobintoro, Expandable stroller, US6676140B1, 2002.

721 [65] J. Kinzel, Transport trolley, US20040169353A1, 2002.

722 [66] R. Powers, Child-scalable stroller, US20060290107A1, 2005.

723 [67] Y.-Z.C.-L. Mo, Stroller, US8480115B2, 2009.

724 [68] B.J. Mattarocci, Stroller, US20150001821A1, 2014.

725 [69] L. Shamie, Tandem stroller, US4725071A, 1987.

726 [70] M. Haung, Stroller with double seats, US5664795A, 1995.

727 [71] C.-H. Yang, Multi-seat stroller, US6086087A, 1999.

728 [72] L. Storch, Safety device automatically helps prevent runaway baby strollers,
729 US20140225340A1, 2014.

730 [73] E.S. Alt, Toy vehicle, US2289331A, 1942.

731 [74] V.A. East, Child's vehicle, US2616725A, 1952.

732 [75] R.H.N. Foster, Packaging for umbrella strollers, US9517790B2, 2014.

733 [76] A.C. Risdon, Envelopes, US2979189A, 1958.

734 [77] D.L. Cospers, A support for storing and shipping small boats, US4016976A,
735 1976.

736 [78] T.E. Deaton, Dust mop package, US5566820A, 1995.

737 [79] S. Gilbert, Baby stroller lighting system, US20160009219A1, 2015.

738 [80] D.P. Penello, Portable baby-changing table apparatus attachable to a baby
739 stroller, US9924806B2, 2015.

740 [81] C.B. Kim, Multi-function baby support and transport apparatus, US5234224A,

741 1991.

742 [82] T.E.M.C. Arnold, Stroller accessory bar and drink holder, US5464183A, 1993.

743 [83] R. Grantz, Stroller with fold out changing table, US8480114B1, 2011.

744 [84] T.M.P.R.B.T.Y. TONG, Access optimized child support device,
745 US20160192787A1, 2016.

746 [85] C.P.L.Santosj.H.E.Bartzl.Dudkowskis.M.Maddoxm.C. WANG, Convertible
747 jogging and all-terrain strollers, US9481389B2, 2015.

748 [86] D.B. Miller, Stroller, US20020041083A1, 2001.

749 [87] S.-L. Liu, Front fork swivel control structure of a jogging stroller Abstract,
750 US7083175B1, 2005.

751 [88] T.-Y. Liao, Baby strollers, US9849902B1, 2017.

752 [89] T. Wang, Trolley frame foldable in one-step operation, US5558357A, 1995.

753 [90] L. Ageneau, Child stroller with umbrella type folding, US20060214395A1,
754 2006.

755 [91] M. Golias, Collapsible supporting structure, US20060267303A1, 2006.

756 [92] T.-Y. Liao, Baby stroller, US9988064B2, 2016.

757 [93] M. Golias, Collapsible supporting structure, US7591479B2, 2003.

758 [94] G. Liao, Golf Bag Cart Foldable Device, US20100059948A1, 2008.

759 [95] P.W.L.S. Tian, Stroller with telescopic and locking members,
760 US20140346756A1, 2014.

761 [96] D.W. Gill, Twosome walker-stroller, US2993702A, 1961.

762 [97] A.J. Browning, Suitcase attachment, US3257120A, 1966.

763 [98] H. Andersson, Telescopic guide, especially for transmittance of torque,
764 US4705491A, 1986.

765 [99] C. Perry, Motorized baby stroller, US20180273118A1, 2017.

766 [100] S. Gopaul, Baby stroller, USD833918S1, 2017.

767 [101] Q. Zhang, Collapsible baby carriage, US9834243B1, 2017.

768 [102] J.P. Bosk, Collapsible child's carrier and seat, US2549958A, 1951.

769 [103] T.S. Lindabury, Collapsible stroller, US2429763A, 1947.

770 [104] W. Ernst, Collapsible baby carriage, US2170227A, 1939.

771 [105] D.D. Patterson, Baby strollers, US3365210A, 1968.

772 [106] K.F.D.M. Alicea, Child stroller with directional rocker, US20180346010A1,
773 2018.

774 [107] C.H.R.R.A.S.E.Y.M. Young, Convertible stroller, USD825400S1, 2018.

775 [108] R.C. Everett, Infant jogging stroller, USD463762S1, 2002.
776 [109] S.W. Leu, Collapsible frame assembly and stroller, US5364119A, 1993.
777 [110] R.C. Everett, Collapsible baby stroller for a jogger, USD419113S, 1999.
778 [111] M. Abreu, Temperature-Controlled Stroller, US20180236913A1, 2018.
779 [112] U.N. Sehat, A.R., State of the art baby strollers: Design review and the
780 innovations of an ergonomic baby stroller, (2017) 55.
781 [113] MAMOURS, Stroller, (n.d.).
782 <http://www.mamours.com.my/catalog/stroller-malaysia>.
783 [114] J.S.H.T.W.P.L.M.S. Weiss, Ride along board for baby stroller, US8714582B2,
784 2009.
785 [115] C.-F.Y.-F. Yu, Attachment mechanism for stroller tray accessory,
786 US6368006B1, 2011.
787
788

UNDER PEER REVIEW