Original Research Article

Characterization and evolution of Dishevelled genes in *Paralichthys olivaceus*

Formatted: Font: Italic

Running title: Characterization and evolution of *Dishevelled*

ABSTRACT

Dishevelled (Dvl or Dsh) is a family of cytoplasmic proteins that serves as signal transducers in Wnt signaling pathways, and plays important roles in development and carcinogenesis. In this paper, we This gene (*Dvl*) was characterized in the flat fish *Paralichthys olivaceus* for its expression pattern, characterized the expression pattern, structure and phylogenetics, of *Dvl* genes in the flatfish *Paralichthys olivaceus*. Three We cloned three gene paralogues (*Dvl1*, *Dvl2* and *Dvl3*) of the *Dvl* family were cloned in *P. olivaceus* and discovered an a N-terminal DAX domain, a central PDZ domain and a C-terminal DEP domain were discovered in all three protein paralogues. Phylogenetic analysis revealed that *Dvl* genes in *P. olivaceus* are most closely related to those in marine teleosts *Larimichthys crocea* and *Stegastes partitus*, followed by those in *Cynoglossus semilaevis*, and that for each *Dvl* gene, those in teleosts fall into a clade independent from those in other vertebrates, suggesting that the duplication of *Dvl* genes occurred prior to the divergence of vertebrates. A pilot study on the In this study, we for the first time characterized the temporal expression characterization patterns of the three *Dvl* genes during the embryonic development of teleosts. In *P. olivaceus*, all

Comment [S1]: Write in full and acronym in bracket

three *Dvl* genes remain at low expression levels during the early stages of development until gastrula stage, when the expression of *Dvll* was significantly up-regulated. ~~Compared with previous studies conducted in mammals, The our~~ research revealed vastly different temporal expression patterns of *Dvl* genes. ~~Taken together with previous studies, our results~~ suggested that the structure of Dvl proteins is conserved, but the expression patterns of *Dvl* genes vary significantly among different classes.

Keywords: *Dishevelled*; *Paralichthys olivaceus*; expression; phylogenetics

INTRODUCTION

Disheveled (Dvl or Dsh) is a family of cytoplasmic phosphoprotein that acts as the signal transducer in Wnt signaling pathways. To date, three genes encoding Dvl protein isoforms have been discovered in most vertebrates (Hotta *et al.*, 2003). They belong to a multi-gene family and are possibly the results of both genome duplication and gene loss (Gray *et al.*, 2009).

Wnt signaling pathways are a type of highly conserved signal transduction pathway existing in a wide variety of species ranging from *Caenorhabditis elegans* to human (Nusse, 2005), and are involved in physiological processes including early embryonic development, cell polarity establishment, tissue regeneration and the development of the reproductive system (Logan and Nusse, 2004).

Three Wnt signaling pathways have been characterized: the canonical Wnt/ β -catenin signaling pathway, which activates the transcription of downstream genes by promoting the nuclear import of β -catenin; the non-canonical Wnt/PCP signaling pathway, which regulates actin modification by G protein-mediated activation of JNK,

Comment [S2]: Write in full and abbreviate subsequently

and the non-canonical Wnt/Ca²⁺ signaling pathway, which regulates cell adhesion and gene expression by releasing intracellular calcium (Clevers, 2006).

The activation mechanisms of the three Wnt pathways are identical, with extracellular Wnt protein binding to a Frizzled family receptor and a co-receptor, subsequently passing external signals to the cytoplasmic Dvl proteins. In the canonical Wnt signaling pathway, Dvls inhibit the degradation of β -catenin by prohibiting the assembly of proteins adenomatous polyposis coli, Axin and glycogen synthase kinase-3 β into the destruction complex. The accumulation of cytoplasmic β -catenin leads to its increased nuclear import and subsequent binding with transcription factors TCF/LEF, thus promoting the transcription of downstream genes (Logan and Nusse, 2004).

In addition to being critical positive regulators of the three Wnt signaling pathways, Dvls are able to interact with proteins of other signaling pathways, thus enabling the cross-talk between Wnt and other pathways (Inobe *et al.*, 1999; Chen *et al.*, 2001; Hocesvar *et al.*, 2003).

Though the functions and expression patterns of *Dvl* genes have long been subjected to intensive study due to their medical and developmental significance, quantitative research concerning the expression levels of *Dvl* genes in vertebrate embryos were limited to several type species including mouse, chicken and *Xenopus* (Park *et al.*, 2005; Lee *et al.*, 2008; Gray *et al.*, 2009). Moreover, the vast majority of these studies revealed only the spatial, but not temporal, expression patterns. The only research to date concerning the temporal expression patterns of *Dvl* genes during embryonic

development was conducted in rhesus monkey by Zheng *et al.* (2006), but only *Dvl1* and *Dvl2* were characterized and data after blastocyst hatching were not obtained due to technical constraints.

P. olivaceus is one of the most important cultured marine flatfish species in East Asia and takes up a considerable proportion in Asian fish markets. *P. olivaceus* have been the subject of extensive study since the 1970s, mainly focusing on sexual differentiation (Fan *et al.*, 2017; Liang *et al.*, 2017), pathology (Kim *et al.*, 2015; Hwang *et al.*, 2016) and metamorphosis (Zhang *et al.*, 2011; Fu *et al.*, 2013). Studies concerning several signaling pathways have also been conducted (Niu *et al.*, 2015; Li *et al.*, 2017). However, the role and expression pattern of Wnt pathway genes during embryonic development in *P. olivaceus* have remained unknown.

~~In this paper, we cloned three genes (*Dvl1*, *Dvl2* and *Dvl3*) of the *Dvl* family in *P. olivaceus* and conducted initial research including sequence alignment, protein structure prediction and phylogenetic analysis. We also conducted the first study concerning the temporal expression patterns of three *Dvl* genes during all stages of embryonic development in vertebrates and the first quantitative characterization of *Dvl* gene expression in teleosts. Our study serves as the foundation of further research into the role of *Dvl* during the early development in vertebrates, especially teleosts, and its status in molecular evolution.~~

MATERIALS AND METHODS

Embryo collection

P. olivaceus eggs obtained from the Yellow Sea Aquatic Product Co., Ltd. were fertilized *in vitro* in 22°C (±1°C) filtered seawater and underwent subsequent stages of development in normal seawater. Embryos of fifteen developmental stages (fertilized egg, 2-cell stage, 16-cell stage, morula, high blastula, low blastula, early gastrula, late gastrula, neurula, tailbud stage, during hatching, post hatching, 12hph, 24hph, 36hph) and larvae were sampled. Every thirty larvae or embryos of the same stage were collected in a 1.5mL centrifuge tube and were rinsed twice by PBS. Rinsed specimens were quick-frozen with liquid nitrogen and preserved at -80°C. Experimental protocols were approved by the Animal Care and Use Committee of Ocean University of China.

RNA extraction and cDNA synthesis

Total RNA from *P. olivaceus* embryos and larvae were extracted with TRIzol reagent (Invitrogen, Carlsbad, USA) according to the manufacturer's protocol. RNA was purified by the removal of DNA and protein using DNaseI (Takara Biotechnology, Dalian, China) and BIOMED RNA clean-up kit (BIOMED, Beijing, China). cDNA was synthesized by the M-MLV reverse transcription system (Takara Biotechnology, Dalian, China).

Protein domain prediction and analysis

The conserved domains of the Dvl family proteins in *P. olivaceus* were predicted on SMART. Primary structure of the conserved domains were illustrated according to the results.

Phylogenetic analysis

In order to investigate the evolutionary relationships of the three *Dvl* genes between

Comment [S3]: State the country

P. olivaceus and other vertebrates, we conducted molecular phylogenetic analysis based on protein sequences. Amino acid sequences of Dvl proteins in vertebrates were acquired from NCBI (<http://www.ncbi.nlm.nih.gov/nucleotide/?term=Dvl>). Apart from the protein sequences of *P. olivaceus*, we also utilized the sequences of *Danio rerio*, *Cynoglossus semilaevis*, *Larimichthys crocea* and *Stegastes partitus*, representing teleosts, *Xenopus laevis*, representing amphibians, and *Mus musculus* and *Homo sapiens*, representing mammals, for further analysis. Utilizing the MEGA6 software, we constructed the phylogenetic tree based on the neighbor joining calculation method.

qRT-PCR assay

cDNA acquired through *in vitro* reverse transcription was diluted to 20 ng/μL and was used as the template for qRT-PCR. Primers of fluorescent quantitative PCR designed on IDT were as follows:

Dvl-1-Fw: TTGACGACTTGCCTTTATCTGC;

Dvl-1-Rv: TCTCAGGTAGCCGTGTTTCAG;

Dvl-2-Fw: TCTGTGACTCCGAGGATGACG;

Dvl-2-Rv: CCCACAATACTGATGCAAG;

Dvl-3-Fw: CCAGTTCTCTGTTGGGAGTTT;

Dvl-3-Rv: CGTTACGCCAGCCTTTCTAT.

18S rRNA was chosen as the reference gene, with primers being:

18S rRNA-Fw: GGTAACGGGGAATCAGGGT;

18S rRNA-Rv: TGCCTTCCTTGGATGTGGT.

qRT-PCR amplification was carried out on LightCycler 480 (Roche Applied Science,

Penzberg, Germany) with Taq polymerase (Takara Biotechnology, Dalian, China) under the following conditions: 95°C (5 min) and 45 cycles of 95°C (15 s) and 60°C (45 s). cDNA from each stage was amplified for three times and the results were averaged to represent the expression level of the certain stage.

Data analysis

Copy numbers of both *Dvl* genes and reference genes were calculated based on the $2^{-\Delta\Delta CT}$ method. Further calculation revealed the relative expression of *Dvl* genes during each stage. Prism 6 and SPSS 20.0 were utilized for data analysis and illustration and significance analysis, respectively.

RESULTS

Dvl protein domains

The sequences of three *Dvl* genes, encoding 559, 768 and 785 amino acids, respectively, in *P. olivaceus* were obtained through molecular cloning. Protein domain prediction by SMART revealed the existence of an N-terminal DAX domain, a central PDZ domain and a C-terminal DEP domain in proteins encoded by all three genes, which is consistent with previous studies (Boutros and Mlodzik, 1999). The molecular weight of each domain was highly conserved (Fig. 1).

Though the open reading frames of the three *Dvl* genes displayed low overall homology, the amino acid sequences at the three predicted domains showed relatively high sequence identity (Fig. 2).

The results above indicate that the structure of the three proteins encoded by the *Dvl*

family genes was highly conserved among distinct species and may therefore share, at least some, similar functions.

Evolutionary relationships of the Dvl gene family

To reveal the evolutionary relationships of *Dvl* genes between *P. olivaceus* and other vertebrates, we constructed the molecular phylogenetic tree consisting of three *Dvl* genes in *D. rerio*, *C. semilaevis*, *P. olivaceus*, *L. crocea*, *S. partitus*, *X. laevis*, *M. musculus* and *H. sapiens*.

As is shown in Fig 3., the three *Dvl* genes fall into three distinct clades, with the clades of *Dvl2* and *Dvl3* combining into a larger clade diverged from that of *Dvl1*. For each *Dvl* paralogue, genes in teleosts and those in other vertebrates fall into two distinct clades, suggesting that the duplication of *Dvl* genes occurred prior to the divergence of vertebrates.

Dvl1 and *Dvl2* in *P. olivaceus* fall into one clade first with those of *L. crocea* and *S. partitus*, and subsequently with those of *C. semilaevis*, while the freshwater fish *D. rerio* is on the edge of the teleost clade, differing significantly from the marine teleosts. Curiously, *Dvl3* in *S. partitus* and *C. semilaevis* fall into a clade independent from all other clades.

The expression patterns of Dvl genes during early development

The quantitative results of qRT-PCR reveals the temporal expression patterns of *Dvl* genes during the early development of *P. olivaceus* (Fig. 4).

The expression level of *Dvl1* is low until gastrula stage, but is dramatically up-regulated thereafter, indicating the initiation of the zygotic *Dvl1* gene expression.

The expression level of *Dvl1* reaches a peak during hatching, followed by a decline thereafter, and eventually resume to high level at 12h post hatching.

The expression of both *Dvl2* and *Dvl3* remains at low levels during embryonic development and displays similar trends in the early stages. The expression levels of the two genes both show a downward trend until 2-cell stage and rise thereafter. During gastrula stage there is another decline and in the somites stage, the expression levels rise significantly. The expression levels of both genes are down-regulated after hatching and rises again at 36h post hatching (*Dvl2*) and 12h post hatching (*Dvl3*), respectively.

DISCUSSION

Being ubiquitous among both invertebrates and vertebrates (Cadigan and Nusse, 1997), the highly conserved Wnt signaling pathways play a vital role in the regulation of the physiological activities in animals and their malfunction would result in embryo developmental disorders (Perrimon and Mahowald, 1987; Wang *et al.*, 2012) and carcinogenesis (Howe and Brown, 2004; Polakis, 2007). As a positive regulator in Wnt signaling, Dvl initiates the transcription of downstream genes by inhibiting the degradation of cytoplasmic β -catenin (Gao and Chen, 2010). The abnormal expression of *Dvl* genes would result in the disruption of Wnt signaling pathways and eventually lead to disorders and diseases (Huang *et al.*, 2013; White *et al.*, 2015).

Three isoforms of the cytoplasmic phosphoprotein Dvl have yet been characterized in mammals, all of them comprise 600 to 700 amino acids (Lijam and Sussman, 1995).

Three highly conserved domains in Dvl proteins have been described. The N-terminal DAX domain mediates homopolymerization and the interaction between Dvl and Axin (Fiedler *et al.*, 2011). The central PDZ domain binds with CKI and is the activator of the Wnt signaling pathway (Peters *et al.*, 1999; McKay *et al.*, 2001). The C-terminal DEP domain functions as the signal transducer in the Wnt signaling pathway, and is the regulator of cell polarity (Wong *et al.*, 2000; Consonni *et al.*, 2014). In our research, we discovered the three aforementioned domains in all three *P. olivaceus* Dvl isoforms, suggesting that the Dvls are highly conserved between distinct species.

The phylogenetic tree constructed on the basis of amino acid sequence alignment has revealed that the divergence of genes *Dvl2* and *Dvl3* occurred after their split from the clade of *Dvl1*, therefore *Dvl2* and *Dvl3* share higher levels of identity in terms of evolutionary relationships.

It has been proposed that the diversification of vertebrate genes was caused by two rounds (2R) of whole-genome duplication (WGD) during the early evolution of deuterostomes (Dehal and Boore, 2005; Gray *et al.*, 2009). However, a third round of WGD, restricted to teleosts, was thought to have occurred after the divergence of teleosts and other vertebrates (Meyer and van de Peer, 2005). This third duplication, named as the fish-specific genome duplication (FSGD), has been supported by various comparative genomics studies (Amores *et al.*, 1998; Guo *et al.*, 2011).

According to the 2R theory, the ancestral *Dvl* gene duplicated during the first round of WGD, giving rise to two paralogues *Dvl1/4* and *Dvl2/3*. The two paralogues underwent a second stage of WGD and produced *Dvl1*, *Dvl2*, *Dvl3* and *Dvl4*. *Dvl4* was

lost and consequently only three paralogues remained (Gray *et al.*, 2009). If the FSGD did occur, there should be at least three more *Dvl* paralogues in ray-finned fishes. However, no fish species with more than three *Dvl* paralogues has been discovered to date (Hotta *et al.*, 2003). It could be hypothesized that the *Dvl* genes produced by 2R were duplicated during the FSGD but subsequently underwent a massive gene loss, resulting in the elimination of three to five *Dvl* paralogues. However, ~~our research, along with similar to~~ previous studies (Gray *et al.*, 2009), ~~obtained~~ no results ~~was obtained to that can~~ substantiate this hypothesis. As a result, ~~we are still unable to rule out~~ the possibility ~~of that the so-called~~ FSGD ~~being was in fact~~ the result of massive local duplication ~~cannot be ruled out~~.

~~An intriguing result of our research is that the~~ The clade containing the *Dvl3* genes in *C. semilaevis* and *S. partitus* split from the clade of other *Dvl* genes before the divergence of *Dvl1*, *Dvl2* and *Dvl3* ~~was intriguing~~. This result indicated~~s~~ that ~~a there might be a~~ local duplication ~~might have~~ taken place prior to the first round of WGD, but was restricted to several species. ~~This may~~ ~~However, this phenomenon is beyond the scope of our paper and~~ requires further exploration.

~~Our study for the first time characterized the~~ Temporal expression patterns of all three *Dvl* gene paralogues during vertebrate embryonic development ~~was characterized for the first time~~. ~~In~~ ~~We show that in~~ *P. olivaceus* embryos, *Dvl1* was expressed at a level far higher than those of *Dvl2* and *Dvl3*. A similar study that characterized the expression patterns of *Dvl1* and *Dvl2* throughout all stages of embryonic development was conducted in rhesus monkey embryos and showed vastly different patterns, with

the expression level of *Dvl2* exceeding that of *Dvl1* until hatching (Zheng *et al.*, 2006). Similarly, another study conducted in human embryonic kidney cells and mouse teratocarcinoma cells showed that the expression level of *Dvl2* much was higher than that of the other two paralogues (Lee *et al.*, 2008). Though the temporal expression patterns of *Dvl* genes in other species remain unexplored, data available to date indicate the possibility that the temporal expression patterns between mammals and teleosts are substantially different due to distinct developmental regulation mechanisms. Moreover, spatial expression patterns of *Dvl* genes during vertebrate embryonic developments have to date been characterized in mouse, chicken, and *Xenopus* and also revealed significant differences between these species (Gray *et al.*, 2009). Taken together, these results possibly indicate that both spatial and temporal expression patterns of *Dvl* genes can to some extent reflect the evolutionary relationships between species.

~~In this paper, we studied the structure and evolution of *Dvl* gene family in *P. olivaceus*, and characterized its expression pattern during early embryonic development. Our study provided insight into the regulation mechanisms of the development of *P. olivaceus* and other teleosts, and may serve as the basis for further research into the evolutionary history of *Dvl* genes.~~

CONCLUSION

REFERENCES

- Amores, A., Force, A., Yan, Y.L., Joly, L., Amemiya, C., Fritz, A., Ho, R.K., Langeland, J., Prince, V., Wang, Y.L., Westerfield, M., Ekker, M. and Postlethwait, J.H., 1998. Zebrafish hox clusters and vertebrate genome evolution. *Science*, **282**: 1711-1714.

-
- Boutros, M. and Mlodzik, M., 1999. Dishevelled: At the crossroads of divergent intracellular signaling pathways. *Mech. Dev.*, **83**: 27-37.
- Cadigan, K.M. and Nusse, R., 1997. Wnt signaling: A common theme in animal development. *Genes Dev.*, **11**: 3286-3305.
- Chen, W., Hu, A.L., Semenov, M.V., Yanagawa, S., Kikuchi, A., Lefkowitz, R.J. and Miller, W.E., 2001. β -Arrestin1 modulates lymphoid enhancer factor transcriptional activity through interaction with phosphorylated dishevelled proteins. *Proc. Natl. Acad. Sci. U.S.A.*, **98**: 14889-14894.
- Clevers, H., 2006. Wnt/ β -catenin signaling in development and disease. *Cell*, **127**: 469-480.
- Consonni, S.V., Maurice, M.M. and Bos, J.L., 2014. DEP domains: Structurally similar but functionally different. *Nat. Rev. Mol. Cell Biol.*, **15**: 357-362.
- Dehal, P. and Boore, J.L., 2005. Two rounds of whole genome duplication in the ancestral vertebrate. *PLoS Biol.*, **3**: e314.
- Fan, Z.F., Zou, Y.X., Jiao, S., Tan, X.G., Wu, Z.H., Liang, D.D., Zhang, P.J. and You, F., 2017. Significant association of *cyp19a* promoter methylation with environmental factors and gonadal differentiation in olive flounder *Paralichthys olivaceus*. *Comp. Biochem. Physiol. A*, **208**: 70-79.
- Fiedler, M., Mendoza-Topaz, C., Rutherford, T.J., Mieszczanek, J. and Bienz, M., 2011. Dishevelled interacts with the DIX domain polymerization interface of Axin to interfere with its function in down-regulating β -catenin. *Proc. Natl. Acad. Sci. U.S.A.*, **108**: 1937-1942.

-
- Fu, Y.S., Shi, Z.Y., Wang, G.Y., Zhang, J.L., Li, W.J. and Jia, L., 2013. Expression of *let-7* microRNAs that are involved in Japanese flounder (*Paralichthys olivaceus*) metamorphosis. *Comp. Biochem. Physiol. B*, **165**: 106-113.
- Gao, C. and Chen, Y.G., 2010. Dishevelled: The hub of Wnt signaling. *Cell Signal.*, **22**: 717-727.
- Gray, R.S., Bayly, R.D., Green, S.A., Agarwala, S., Lowe, C.J. and Wallingford, J.B., 2009. Diversification of the expression patterns and developmental functions of the *Dishevelled* gene family during chordate evolution. *Dev. Dyn.*, **238**: 2044-2057.
- Guo, B.C., Wagner, A. and He, S.P., 2011. Duplicated gene evolution following whole-genome duplication in teleost fish. In: *Gene duplication* (ed. F. Friedberg), Intech Rijeka, Croatia, pp. 27-36.
- Hocevar, B.A., Mou, F., Rennolds, J.L., Morris, S.M., Cooper, J.A. and Howe, P.H., 2003. Regulation of the Wnt signaling pathway by disabled-2 (Dab2). *EMBO J.*, **22**: 3084-3094.
- Hotta, K., Takahashi, H., Ueno, N. and Gojobori, T., 2003. A genome-wide survey of the genes for planar polarity signaling or convergent extension-related genes in *Ciona intestinalis* and phylogenetic comparisons of evolutionary conserved signaling components. *Gene*, **317**: 165-185.
- Howe, L.R. and Brown, A.M.C., 2004. Wnt signaling and breast cancer. *Cancer Biol. Ther.*, **3**: 36-41.
- Huang, M.Y., Yen, L.C., Liu, H.C., Liu, P.P., Chung, F.Y., Wang, T.N., Wang, J.Y. and

-
- Lin, S.R., 2013. Significant overexpression of *DVLI* in Taiwanese colorectal cancer patients with liver metastasis. *Int. J. Mol. Sci.*, **14**: 20492-20507.
- Hwang, J.Y., Kwon, M.G., Seo, J.S., Do, J.W., Park, M.A., Jung, S.H. and Ahn, S.J., 2016. Differentially expressed genes after viral haemorrhagic septicaemia virus infection in olive flounder (*Paralichthys olivaceus*). *Vet. Microbiol.*, **193**: 72-82.
- Inobe, M., Katsube, K., Miyagoe, Y., Nabeshima, Y. and Takeda, S., 1999. Identification of EPS8 as a Dvl1-associated molecule. *Biochem. Biophys. Res. Commun.*, **266**: 216-221.
- Kim, M.S., Park, J.S. and Kim, K.H., 2015. Generation of G gene-deleted viral hemorrhagic septicemia virus (VHSV) and evaluation of its vaccine potential in olive flounder (*Paralichthys olivaceus*). *Fish Shellfish Immunol.*, **45**: 666-671.
- Lee, Y.N., Gao, Y. and Wang, H.Y., 2008. Differential mediation of the Wnt canonical pathway by mammalian Dishevelleds-1, -2, and -3. *Cell Signal.*, **20**: 443-452.
- Li, S., Peng, W.J., Hao, G.X., Li, J.F., Geng, X.Y. and Sun, J.S., 2017. Identification and functional analysis of dual-specificity MAP kinase phosphatase 6 gene (*dusp6*) in response to immune challenges in Japanese flounder *Paralichthys olivaceus*. *Fish Shellfish Immunol.*, **60**: 411-419.
- Liang, D.D., Fan, Z.F., Weng, S.D., Jiao, S., Wu, Z.H., Zou, Y.X., Tan, X.G., Li, J., Zhang, P.J. and You, F., 2017. Characterization and expression of *StAR2a* and *StAR2b* in the olive flounder *Paralichthys olivaceus*. *Gene*, **626**: 1-8.
- Lijam, N. and Sussman, D.J., 1995. Organization and promoter analysis of the mouse *dishevelled-1* gene. *Genome Res.*, **5**: 116-124.

-
- Logan, C.Y. and Nusse, R., 2004. The Wnt signaling pathway in development and disease. *Annu. Rev. Cell Dev. Biol.*, **20**: 781-810.
- McKay, R.M., Peters, J.M. and Graff, J.M., 2001. The casein kinase I family in Wnt signaling. *Dev. Biol.*, **235**: 388-396.
- Meyer, A. and van de Peer, Y., 2005. From 2R to 3R: Evidence for a fish-specific genome duplication (FSGD). *BioEssays*, **27**: 937-945.
- Niu, J.J., Liu, C.H., Yang, F., Wang, Z.W., Wang, B., Zhang, Q.Q., He, Y. and Qi, J., 2015. Characterization and genomic structure of *Dnah9*, and its roles in nodal signaling pathways in the Japanese flounder (*Paralichthys olivaceus*). *Fish Physiol. Biochem.*, **42**: 167-178.
- Nusse, R., 2005. Wnt signaling in disease and in development. *Cell Res.*, **15**: 28-32.
- Park, T.J., Gray, R.S., Sato, A., Habas, R. and Wallingford, J.B., 2005. Subcellular localization and signaling properties of Dishevelled in developing vertebrate embryos. *Curr. Biol.*, **15**: 1039-1044.
- Perrimon, N. and Mahowald, A.P., 1987. Multiple functions of segment polarity genes in *Drosophila*. *Dev. Biol.*, **119**: 587-600.
- Peters, J.M., McKay, R.M., McKay, J.P. and Graff, J.M., 1999. Casein kinase I transduces Wnt signals. *Nature*, **401**: 345-350.
- Polakis, P., 2007. The many ways of Wnt in cancer. *Curr. Opin. Genet. Dev.*, **17**: 45-51.
- Wang, J., Sinha, T. and Wynshaw-Boris, A., 2012. Wnt signaling in mammalian development: Lessons from mouse genetics. *Cold Spring Harb. Perspect. Biol.*, **4**: 5.

White, J., Mazzeu, J.F., Hoischen, A., Jhangiani, S.N., Gambin, T., Alcino, M.C., Penney, S., Saraiva, J.M., Hove, H., Skovby, F., Kayserili, H., Estrella, E., Vulto-van Silfhout, A.T., Steehouwer, M., Muzny, D.M., Sutton, V.R., Gibbs, R.A., Baylor-Hopkins Center for Mendelian Genomics, Lupski, J.R., Brunner, H.G., van Bon, B.W. and Carvalho, C.M., 2015. *DVLI* frameshift mutations clustering in the penultimate exon cause autosomal-dominant Robinow syndrome. *Am. J. Hum. Genet.*, **96**: 612-622.

Wong, H.C., Mao, J.H., Nguyen, J.T., Srinivas, S., Zhang, W.X., Liu, B., Li, L., Wu, D.Q. and Zheng, J., 2000. Structural basis of the recognition of the Dishevelled DEP domain in the Wnt signaling pathway. *Nat. Struct. Mol. Biol.*, **7**: 1178-1184.

Zhang, J.L., Shi, Z.Y., Cheng, Q. and Chen, X.W., 2011. Expression of insulin-like growth factor I receptors at mRNA and protein levels during metamorphosis of Japanese flounder (*Paralichthys olivaceus*). *Gen. Comp. Endocr.*, **173**: 78-85.

Zheng, P., Vassena, R. and Latham, K., 2006. Expression and downregulation of WNT signaling pathway genes in rhesus monkey oocytes and embryos. *Mol. Reprod. Dev.*, **73**: 667-677.

FIGURE LEGENDS

Fig. 1. Conserved domains of the *P. olivaceus* Dvl proteins predicted by SMART.

Fig. 2. Alignment of amino acid sequences in three *P. olivaceus* Dvl proteins. Conserved sequences are highlighted in black.

Fig. 3. The phylogenetic tree of *Dvl* genes in vertebrates.

Fig. 4. Relative expression levels (mean±SEM) of the three *Dvl* genes during *P.*

olivaceus embryonic development based on results from qRT-PCR. Abbreviations: fe, fertilized egg; blas, blastula; gas, gastrula.

Figure 1

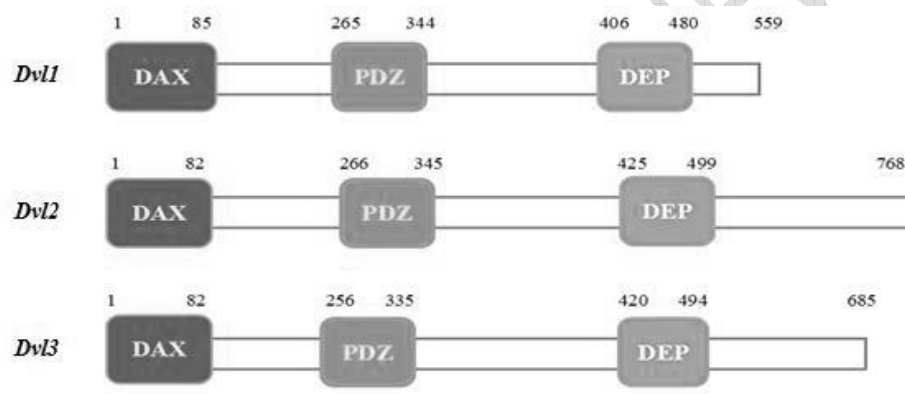

Figure 2

DAX

~~~~~  
*PoDul-1* MAETKIIYHLDEEETPYLVKIPIAAENITLDFKQVLNKP---NYKFFFKSMDQDFGVVKEEISDDNAKLPCFNG  
*PoDul-2* MGETKIIYHLDDQETPYLVKIVSPADKCTLADFKNVLKKP---NYKFFFKSMDQDFGVVKEEISDDNAKLPCFNG  
*PoDul-3* MAETKIIYHLDEEETPYLVKLSVSPEKVTLADFKNVLNRRPVNSYKFFFKSMDQDFGVVKEEISDDNAKLPCFNG

*DAX*

~~~~~  
PoDul-1 RVVSWLWSSDTPAAEPPVAVVPPVETTQFSPFPPPLPPPPAERTGGIGDSRPPSFPNATGSVETLDDQTEFES
PoDul-2 RVVSWLWSSDGAHTDT----GSVADSIETP-----LERTGGIGDSRPPSHGKAASVRDSLNDTEFES
PoDul-3 RVVSWLWLAESAHSDG----GSQCTESHRELPP-----LERTGGIGDSRPPSFHANAVSSRDGLDTEFES

PDZ

~~~~~  
*PoDul-1* STASRLKRRRRRRR-KQRPPRLEASSFSSVTDSTMSLNIITVTLNMEKYNFLGISIVGQSNERGDGGIYIGSIM  
*PoDul-2* S-S SRLMRRRRRRRRKPKASNIDRSSSFSSITDSTMSLNIITVTLNTEKYNFLGISIVGQSNERGDGGIYIGSIM  
*PoDul-3* SSSHLMRRRRRRRRRHKVAKIDRSSSFSSITDSTMSLNIITVTLNMEKYNFLGISIVGQSNDRGDGGIYIGSIM

*PDZ*

~~~~~  
PoDul-1 KGGAAADGRIEPGDMLLQVNDINFENMSNDDAVRVLREIVHKGPIILTVAKCWDPPSPQGYETLFRNEPIRPIID
PoDul-2 KGGAAADGRIEPGDMLLQVNDINFENMSNDDAVRVLREIVHKGPIILTVAKCWDPPNPRGCFALPRSEPIRPIID
PoDul-3 KGGAAADGRIEPGDMLLQVNDINFENMSNDDAVRVLREIVSKTGPISLTVAKCWDPPSRSYETLFRNEPIRPIID

DEP

~~~~~  
*PoDul-1* PAAWVSHSVAMTCGYPPYPGSSSLTIITS----SSSVTETERFDDFNLSLHS-DMASVAKAMASFESGLEVRDR  
*PoDul-2* PAAWVSHSITAMTCGYPPYGMSPMSMTVTSTSSSISSIPETERFDDFNLHLS-DMATVAKAMACEFSGLEVRDR  
*PoDul-3* PAAWISHTTALTCGYPPHY-----EFDDLPSASKTDMATIVKVMQLFDSGLEVRDR

*DEP*

~~~~~  
PoDul-1 MWLKITIANAFICSDVVEWL FHHIEGFQDRREARKYASNLLKACFIRHTVNKITFSEQCYYVFGDLSDCENYMAN
PoDul-2 MWLKITIANAFICSDVVEWL FHHIEGFQDRREARKYASNLLKACFIRHTVNKITFSEQCYYVFGDL--CGN-MTH
PoDul-3 MWLKITIANAVIGADVVDWLYSRVEGFKRRRDARKYASSLLKRGYLRHTVNKITFSEQCYYTFGDL--CGN-MAS

Figure 3

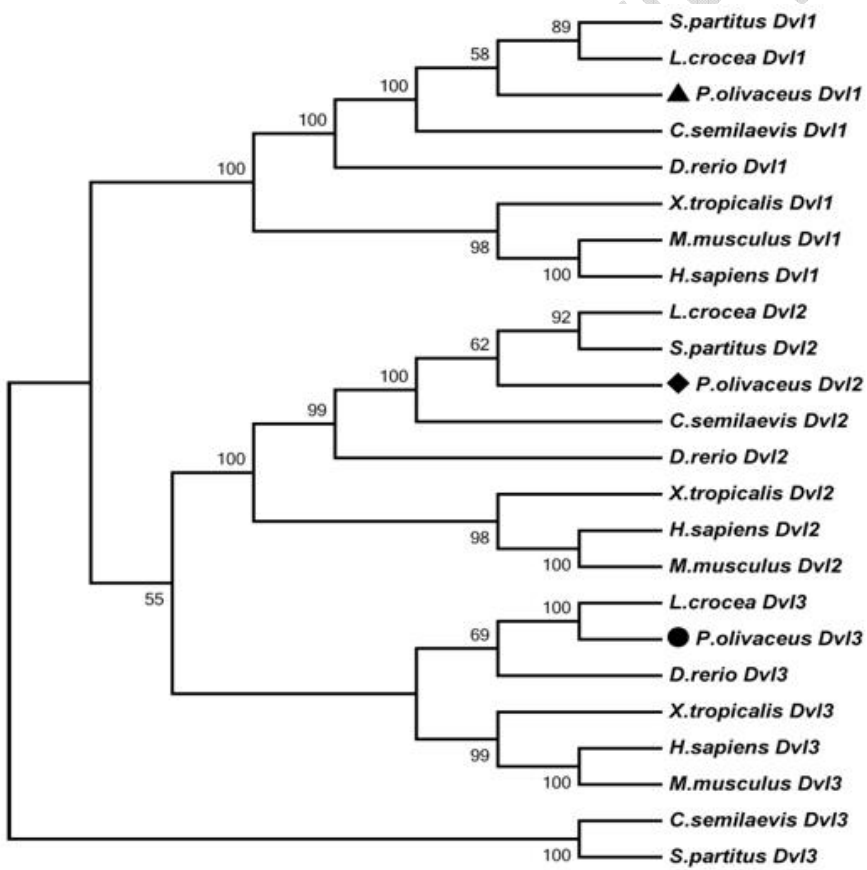
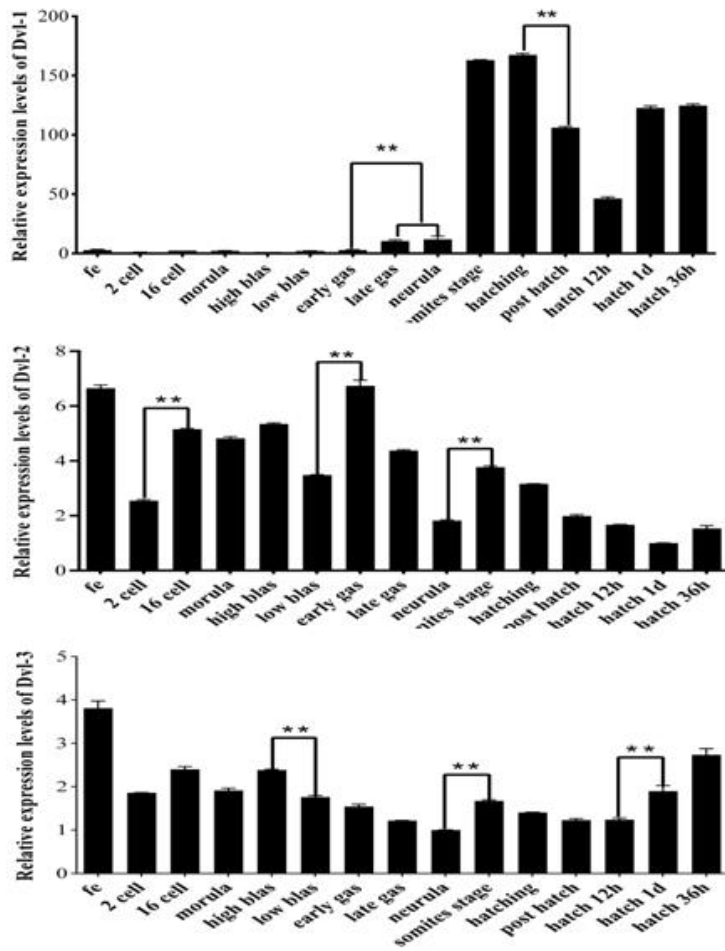

Figure 4



UNDER PEER REVIEW