

**Developments on Baby Strollers over the Last Decade**

**ABSTRACT**

It has come to attention that the interest of baby stroller design is still encouraged and popular among worldwide researches and consumers. A visual history and timeline of invented baby strollers from 1973 to today's baby strollers was drafted. Moreover, a ten years review on multiple designs of baby strollers was done ranging from the year 2008 to 2018. Based on the review, there are many possible ways to design a baby stroller which its sole purpose is to transport a baby in a much easier method. Through this review, it is noticeable that baby stroller inventors are implementing additional functions like rocking mechanism, diaper changing table, and others. The use of electronic devices in strollers is slowly implemented as the years increases, although there always potential ideas for improvements. Graphs and tables on baby strollers by their popularity and brand was drawn with online shopping websites as a resource to recognize consumer's interest. Besides that, potential improvements and ideas on the design and fabrication of baby strollers were suggested to fit in with the impending society and future generation.

**Keywords: Baby stroller; design; fabrication; multi-functional; application; future developments**

**1. Introduction**

The comfort and protection of one's child is every parent's responsibility and a desire to fulfil it. Baby strollers are essential for navigating life with your new baby as it helps to ease the burden of carrying the weight of a baby or toddler on long, or even -short walks. The development of baby stroller throughout the years have improved vastly and significantly, from the form of baby carriages to modern implementations of technology and gadgets. This section of a literature review and research will only be focusing on the designs and applications of baby strollers throughout the many years since it was first invented.

34 The very first baby stroller was invented in the year 1733 by a landscape architect  
35 named William Kent as shown in Figure 1. The purpose of this invention was to  
36 transport the third Duke of Devonshire's children alongside to amuse them. Designed  
37 in a shell-shape, this carriage had a harness aimed to be pulled by animals like goats,  
38 dogs or ponies, with a spring suspension to secure a comfy ride for the baby. Back then,  
39 carriages then become a fashionable piece that only the wealthiest parents could afford.



40

41 **Figure 1: First Baby Carriage Invented by William Kent [1]**

42

43 A century later in the mid-1800s, the baby strollers have become an easier  
44 navigating transport for babies as the designs substituted handles for parents or nannies  
45 to pull the stroller behind her, with the baby facing forward instead of having animals  
46 do the pulling as seen in Figure 2. It has been known that pushing is much easier than  
47 pulling as it takes a lesser strength and energy from one person. Hence, in 1848, baby  
48 stroller came to America and American innovator Charles Burton changed the original  
49 design of the carriage as presented in Figure 3, so parents could push their children  
50 rather than pulling them. The baby stroller was not popular in the United States as  
51 inexperienced parents tended to come into contact with pedestrians. However, he  
52 managed to patent his designs at England with the name “perambulator”, which may be  
53 referred now as pram.

54



55

56

**Figure 2: Carriage in mid 1800s [2]**

57



58

59

**Figure 3: The Perambulator invented by Charles Burton [2]**

60

61 In today's market, the seat of the baby stroller can be adjusted so that parents or  
62 nannies could have the child facing them or facing away from them, whichever they  
63 preferred. This improvement was done by African American inventor William H.  
64 Richardson as he patented his design in the United States in 1889. Richardson made  
65 changes to the carriage wheels allowing it to move independently compared to the  
66 previous non-independent wheels as shown in Figure 4. This improvement makes the  
67 stroller more manoeuvrable and convenient for parents.

68



**Figure 4: Baby carriage invented by Richardson [2]**

69

70

71

72        Slowly, the evolution of baby carriages has been improving. Following World War  
73 I, the safety features on a baby carriages were introduced and updated [3]. Inventors in  
74 1920 made special safety features like bigger wheels, deeper, more spacious, lower and  
75 sturdier frames. Having more space, and lower frames can prevent the baby from  
76 crawling out or decreasing the distance of the stroller and the ground if the baby were to  
77 escape. In the 1930s, materials like plastic and rubber were common materials being  
78 used in manufacturing baby stroller while inexpensive chromes are used as an  
79 alternative to brass. By the 1950s, baby carriages are a must have for parents as  
80 affordable material and safety features are not just a fashion piece but also budget-  
81 friendly [4].

82

83        Came the year 1965 when London design engineer Owen Finlay Maclaren  
84 invented the first umbrella stroller as seen in Figure 5 after watching his daughter  
85 struggled with manoeuvring and travelling with her child and the stroller [5]. Hence, he  
86 invented a lightweight and collapsible structures like how an umbrella works as a new  
87 generation of baby transport. Maclaren strollers are still in the market to date. In 1984,  
88 baby strollers have been made convenient for jogging by replacing the tires to bicycle  
89 tires and design of three-wheeled for a steadier frame. These all was reinvented by Phil  
90 Baechler after receiving reviews from parents whose jogging is a hobby. Lastly, the last  
91 common features we can see in the market today is the double baby stroller developed  
92 by the stroller company Baby Jogger in 1986 as presented in Figure 6.

93



94

95

**Figure 5: First umbrella stroller invented by Owen Maclaren [6]**

96



97

98

**Figure 6: Baby Jogger invented by Phil Baechler [7]**

99

100 Today's stroller in the market has taken most of the original basic features like  
101 ergonomic designs, canopy, rotating wheels, foldable features, rotating seats, and  
102 umbrella strollers. The features are not limited to only the ones that have been stated as  
103 electrical enhancements such as lights, fans and chair warmers have been incorporated  
104 to current baby strollers as well. Figure 7 shows the baby stroller with basic features in  
105 the market today.

106



107

108

**Figure 7: Baby stroller in market today [8]**

109

110 How is a baby stroller, becoming a sophisticated baby transport to cater to the  
111 needs of babies in current society? With the current society where everything involves  
112 technology and electric components, society looks for an easy way to do things. When  
113 the baby feels hot or cold or even irritated, no fan, cushion warmer nor are repellents  
114 needed to be carried around. Why? Because everything is made easier with electrical  
115 components where it can be installed directly to the baby stroller. Strollers now provide  
116 great protection against scorching sun and UV rays as climates are drastically changing  
117 from time to time. What society is looking for its durability and a long-term investment.  
118 A good quality stroller is usually compliant with the firmest safety standards and is  
119 made from strong and durable materials. For example, if parents were to deliver a  
120 new-born baby, they will not be required to purchase another stroller as the existing one  
121 they had before can be used. This is a long-lasting option and it reduces cost greatly for  
122 the adaptation of society today. All in all, parents can feed their baby, entertain them  
123 and regulate baby's temperature with just a baby stroller.

124

125

126 There are tons of baby stroller on the market today as we all know it since it has  
127 been invented in the 1700s. Although the baby stroller has been here for centuries, it is  
128 still a piece that can be creatively improved and a big hit till today. A bar chart as  
129 presented in Figure 8 shows the number of articles and reports regarding designs and  
130 applications of baby strollers. It can be generated through research to prove that baby

131 strollers until 2018 is still trendy. As an engineer, it is our job to always innovate, invent  
132 and design to fulfil objectives and requirements. As shown in the results, baby strollers  
133 can still be improved in design and application wise as parents are still interested with  
134 it.

135

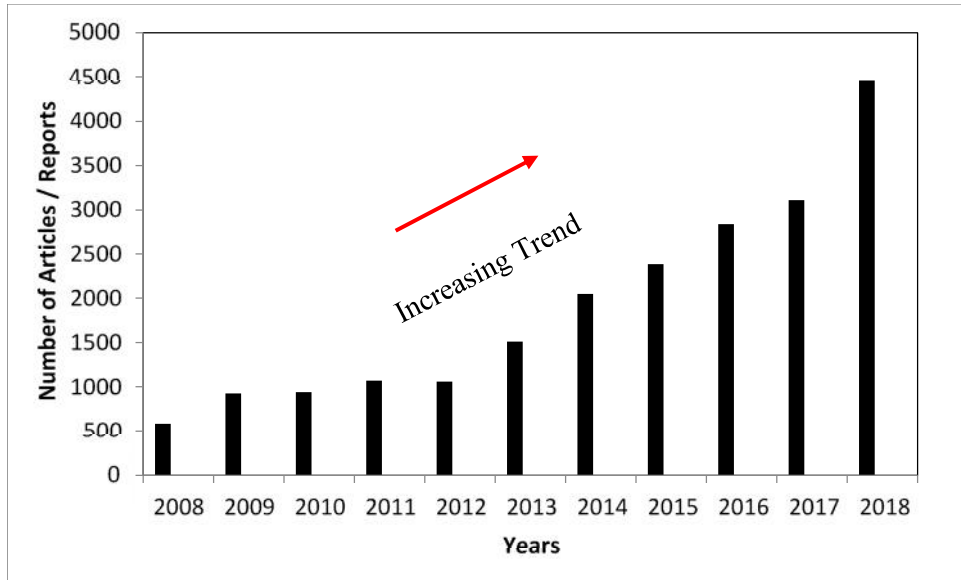

136  
137

Source: Google Search Engine Keywords used: baby stroller, designs, application

138

139 **Figure 8: Number of Articles / reports on baby strollers based on designs and**  
140 **applications for year 2008 - 2018**

141

142 From the above, it can be summarized that the development of baby stroller is still  
143 in great interest among worldwide researches and consumers. Hence, this paper intends  
144 to dedicate a comprehensive review on the improvement of the design and fabrication  
145 or an ergonomic baby stroller from the year 2008 to 2018.

146

147

148

149





171

172

**Figure 10: Baby stroller invented by Thorne, Daley and Koes[10].**

173

174

- iii) The child seat is positioned on the stroller frame as shown in Figure 11. This baby stroller was invented by Robert Pike, Todd Sorzano, Gregory Sellers and Dmitriy Faktorovich. The stroller includes a child barrier that includes a cup holder horizontally. When the child barrier moves relative to the stroller frame, the cup holder pivots horizontally. The user can store their beverage as well as the baby's beverage instead of holding in their hand[13–20].

175

176

177

178

179

180



181

182

**Figure 11: Baby stroller invented by Pike, Sorzano, Sellers and Faktorovich [21].**

183

184

Year 2009

185

186

187

188

189

- i) Baby stroller in Figure 12 was invented by Gerjan Storm. It is a rather simple design for a stroller frame, but it serves its purpose as baby transport system. It consists of three wheels with a baby seat attached in the middle. The seat is attached at the centre of gravity of this baby stroller for better stability.

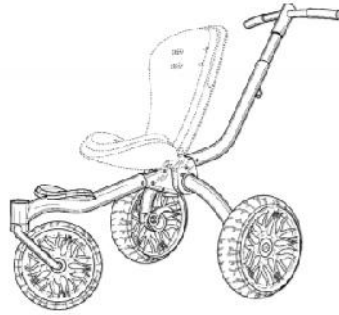

190

191

**Figure 12: Baby stroller invented by Storm [22].**

192

- 193 ii) A deployable side seat for a baby stroller as seen in Figure 13 was invented  
194 by Marie Schutzendorf and Corbett Griffith. An optional removable side  
195 seat for a baby stroller, to seat a second child is secured by hand-operated  
196 connectors to nearly any baby or child stroller without using tools. The side  
197 as can see, it faces to the side to the stroller and has a deployed position in  
198 which two wheels are fixed in tandem on the side seat frame contact the  
199 pavement. The side seat can be folded neatly and compactly when not in  
200 use[23–25].



201

202

**Figure 13: Baby stroller invented by Schutzendorf and Griffith [23].**

203

- 204 iii) This rather interesting baby stroller design as shown in Figure 14 was  
205 invented by Martin Troup and Groner Troup. This baby stroller was made  
206 with the intention to allow the child to seat, stand or in reclined position.  
207 Moreover, it is fully collapsible. The stroller has opposing side walls, a  
208 front wall, a seat and a floor member suspended below the seat. This stroller

209 is supported by four wheels, has a canopy, a standing space formed between  
210 a front edge of the seat base and the handrail to allow the child sufficient  
211 room for standing while holding the handrail [26–28].



212  
213 **Figure 14: Baby stroller invented by Troup[26].**

214

215 Year 2010

216 i) Inventor Jian-Qun Li designed a tandem stroller as in Figure 15. The  
217 objective of this invention is to provide a tandem stroller that has a  
218 shortened length in a front -to-rear direction. The front seat includes a front  
219 seat plate disposed on the frame that can place beverages on it.  
220 Consequently, the total length of the stroller in a front to rear direction is  
221 shortened significantly[29,30].



222

223 **Figure 15: Baby stroller invented by Li [29].**

224

225 ii) Figure 16 shows a stroller that includes a frame having at least one front leg,  
226 one rear leg and at least one wheel mounted on each leg. The inventors are  
227 Jeff Greger and Michael Longnecker. The stroller includes a seat having a  
228 seat base and a seat back pivotally mounted to the frame. The frame for the  
229 baby seat is rather low and spacious to support the size of the travel  
230 attachment[31–33].

231



232

233 **Figure 16: Baby stroller invented by Greger and Longnecker[31].**

234

235 iii) Inventors Wes Thomas, Toriono Granger and James Morrow invented baby  
236 stroller in Figure 17 with the purpose of having the child to seat or stand on  
237 this two in one stroller. The stroller includes a frame and a seat having a  
238 seat pan that is pivotable between a raised and lowered position. In the  
239 lowered position, the seat pan is to support the child in a seating position.  
240 The standing position is allowed due to the foot platform coupled to the  
241 frame[34].



242

243 **Figure 17: Baby stroller invented by Thomas, Granger and Morrow[34].**

244

245 Year 2011

246 i) Gerald Gross has designed an illuminable baby stroller having embedded  
247 light sources as shown in Figure 18 which can control the lights. LEDs are  
248 preferably used as light sources embedded in the frame of the stroller in  
249 translucent sections of the frames making the stroller visible in dim and dark  
250 lighting. This stroller includes a forward and rear light source that  
251 illuminates the path in front and the back of the stroller[35–39].

252



253

254 **Figure 18: Baby stroller invented by Gross [35].**

255

256 ii) The objective of this invention of baby stroller as shown in Figure 19 is to  
257 overcome the shortcomings of the conventional stroller that has a handle bar  
258 that is not adjustable and a bulky shape that is difficult for storage. Chin-I  
259 Lai the inventor improved the shortcomings by including a handle set

260 containing an elevation set and a folding set. The elevation serves its  
261 purpose by allowing adjustments to the length while the folding set allows  
262 the baby stroller to shrunk into a smaller size when folding[40–42].



263  
264 **Figure 19: Baby stroller invented by Lai [40].**

265

266 Year 2012

267 i) This combined shopping trolley baby stroller in Figure 20 was designed by  
268 Harri Ektron. This baby stroller/cart includes a four-wheeled cross-shaped  
269 frame that carries a box-shaped basket and a child seat. The basket can be  
270 changed to half volume and thus can form a child's seat used in the front  
271 seat of cart. The baby stroller seat can be removed to form a full shopping  
272 car to be used[43–47].

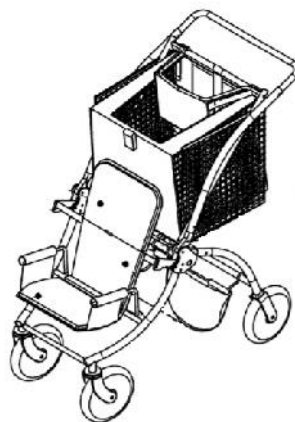

273

274

275 **Figure 20: Baby stroller invented by Ektron [43].**

275

276 ii) Figure 21 represents a stroller designed for people with interest in sports.  
277 The baby stroller was designed by Jean-Pierre Joubert with the idea of  
278 having an athletic accessory container built into the baby stroller. The baby  
279 stroller includes a frame having a front-forward facing seat for infants to be  
280 seated. An enclosure area is defined by a cross-member that spans the  
281 spaced apart frame members. An athletic container is carried on the support  
282 and extends through the enclosure area[48–51].

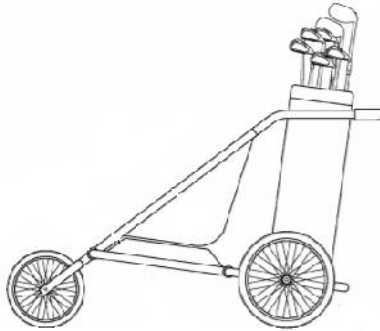

283

284

**Figure 21: Baby stroller invented by Joubert [48].**

285

286 iii) Baby stroller presented in Figure 22 is an automatically controllable smart  
287 stroller invented by Chih-Hsiung Yang. This baby stroller includes a frame,  
288 a body-movement detecting unit provided on the frame, a drive control unit  
289 and a drive unit. The drive control unit electrically connects with the body  
290 movement detecting unit and drive unit. The objective of this baby stroller is  
291 to provide an automatically smart stroller with a synchronous drive  
292 mechanism[52–56].



293

294

**Figure 22: Baby stroller invented by Yang [52].**

295 Year 2013

296 i) This baby stroller in Figure 23 was designed by Mark Zehfuss and Gordon  
297 Liao and was inspired to form a baby stroller with a stroller frame and a  
298 chair. The stroller frame has a rotatable base and the chair includes a folding  
299 joint such that the chair can be folded directly onto the stroller frame to  
300 provide a simple and easy quick operation to accomplish the effect of  
301 reducing the storage volume of a baby stroller. The chair may be mounted  
302 facing forward or rearward [57–60].

303



304

305 **Figure 23: Baby stroller invented by Zehfuss and Liao [57].**

306

307 ii) The present invention as shown in Figure 24 was invented by Cheng-Fan  
308 Yang, Chen-Tai Chang, Sheng-Po Hung and Fu-Peng Chou. This baby  
309 stroller can be extended horizontally and tucked back in. It is a convertible  
310 tandem stroller frame, especially to a convertible tandem stroller frame  
311 equipped with a release actuator mounted at the front end of it lock and  
312 un-lock a longitudinal telescopic mechanism[61–65].



313

314 **Figure 24: Baby stroller invented by Yang, Chang, Hung and Chou [61].**

315

316 Year 2014

317 i) A rather unique baby stroller as shown in Figure 25 was designed by  
318 Bradley James Mattarocci where it includes a platform that the child can  
319 stand on. This stroller consists of a frame, a plurality of wheels supporting  
320 the frame, a forward and rearward facing seat supported by the frame, seat  
321 back and platform positioned rearward of the forward-facing seat. The seat  
322 back helps to support the back if the child seated in the rearward facing seat  
323 in the rearward direction. In addition, the seat is moveable between a use  
324 and storage position to increase child's access to stand on the platform  
325 [66–69].

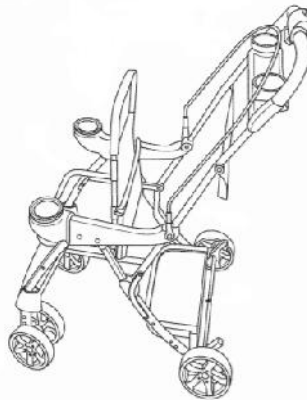

326

327 **Figure 25: Baby stroller invented by Mattarocci [66].**

328

329 ii) Baby stroller presented in Figure 26 has a sole purpose of enhancing the  
330 safety of baby strollers by implementing a safety device that prevents  
331 runaway baby stroller. This baby stroller is very useful especially on rainy

332 days as sidewalks can be slippery and pose a threat on the stroller wheels if  
333 person pushing the stroller stops and doesn't apply brakes. Baby stroller  
334 designed by Leonard Storch has improved the baby stroller by providing  
335 fully automatic slip-clutch joining means to inhibit veering off by  
336 automatically coupling the stroller's rear wheels together when the stroller  
337 is stopped. Once it has been coupled, the rear wheels must rotate in unison  
338 thus helping to prevent the stroller from veering off towards the curb. The  
339 slip clutch disengages when the stroller is being pushed [70–72].

340



341

342 **Figure 26: Baby stroller invented by Storch [70].**

343

344 iii) Baby stroller in Figure 27 was designed with a purpose for better storage.  
345 Ryan Hawker and David N Foster are the inventors behind this baby stroller  
346 design. The seat-frame assembly can be rearranged at the option of the user  
347 to change from expanded use mode to a relatively narrowed collapsed  
348 storage mode [73–76].

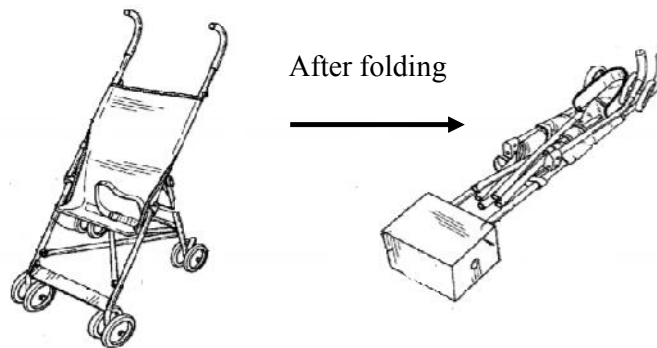

349

350

**Figure 27: Baby stroller invented by Hawker and Foster [73].**

351 Year 2015

352 i) Figure 28 shows a baby stroller invented by Sean Gilbert that incorporates a  
353 lighting system to the stroller. The lighting system can be found underside  
354 of the stroller, comprising a fasten able light strip. A wiring harness  
355 fasten able to the frame of the stroller that is wire configured to electrically  
356 connect the light strip to the power supply. This baby stroller has a switch  
357 integrated to it to activate and deactivate the light strip whereby, when the it  
358 is on active mode, the ground beneath the baby stroller is illuminated.



359

360 **Figure 28: Baby stroller invented by Gilbert [77].**

361

362 ii) This baby stroller presented in Figure 29 is a portable, foldable,  
363 baby-changing table unit is provided attachable to a baby stroller. It is  
364 invented by Daniel and Magdalini Penello. This unit includes connectors for  
365 connecting the baby-changing table unit to the stroller's baby car seat  
366 connectors. A flexible changing pad to be attached to the portable  
367 baby-changing table unit includes a diaper receiver and a handy-wipe  
368 receiver [78–82].



369

370

**Figure 29: Baby stroller invented by Penello [78].**

371

372 iii) Baby stroller in Figure 30 is a convertible jogger and all-terrain stroller  
373 invented by P. Leys, Santos, Hei, E.Bartz, Dudkowski, Maddox, and  
374 C.Wang. This stroller can be used in two modes which are for jogging and  
375 another for everyday use. The seat base is operable to suit the stated modes.  
376 The everyday mode has a relatively short base and high profile while for the  
377 jogging mode have a long base and low profile. The baby stroller includes  
378 3 wheels, one at the front and two at the rear [83–85].



379

**Figure 30: Baby stroller invented by Leys, Santos, Hei, E.Bartz, Dudkowski,  
381 Maddox, and C.Wang [83].**

382

383

384

385 Year 2016

386 i) This baby stroller in Figure 31 was designed by Tsoung-Yong Liao and he  
387 has invented this with an expanded or folded mode. The sole purpose of this  
388 invention is to minimize storage space and for easier transportation by  
389 reducing the slide block and the couplings between components. This baby  
390 stroller is folded part by part to get a flat square like shape in the end. This  
391 stroller is packed with a lower frame, a slide block, a pull rod set, a rear  
392 wheel link rod and frame, first and second handle rod set, and a front wheel  
393 frame [86–89].

394



395

396 **Figure 31: Baby stroller invented by Liao [86].**

397

398 ii) Provided in Figure 32 below, this baby stroller special function is its folding  
399 mechanism that allows occupies less space, improve its portability facilitate  
400 its storage and transportation. This stroller is built upon couplings between  
401 the slide block and rear wheel rocker arms, the handling tube, an upper  
402 frame that assist in this expanded and folded mode. Tsoung-Yong Liao from  
403 Tainan is the man behind this invention [90–92].

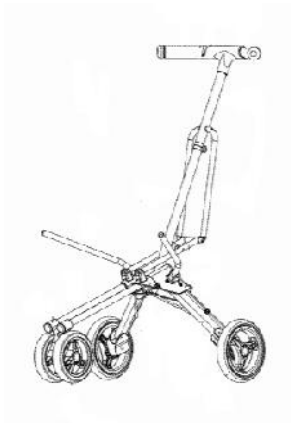

404

405

**Figure 32: Baby stroller invented by Liao [90].**

406

407       iii)    The baby stroller in Figure 33 is a stroller with telescopic and locking  
408                   members invented by Patrick Laffan, Leslie Stiba, and Hao Tian. A stroller  
409                   comprising an additional storage area or child support system when  
410                   expanded. The frames include a mechanism whereby the base of the frame  
411                   is expanded backwards to create more storage space behind the baby seat.  
412                   The stroller may include detachable wheels and handles or push bars that  
413                   can assist in expanding and contracting the storage area [93–96].



414

415

**Figure 33: Baby stroller invented by Laffan, Stiba and Tian [93].**

416

417

418

419

420 Year 2017

421 i) Corban Perry invented a motorized baby stroller as shown in Figure.34 A  
422 motorized baby stroller for transporting a baby may include a front section,  
423 a side section connected to the front and back section. The front section  
424 includes a cavity to hold the baby and includes a proximity detector to detect  
425 a baby in the cavity and control the motors. It has a control panel that might  
426 include a switch and a battery meter.

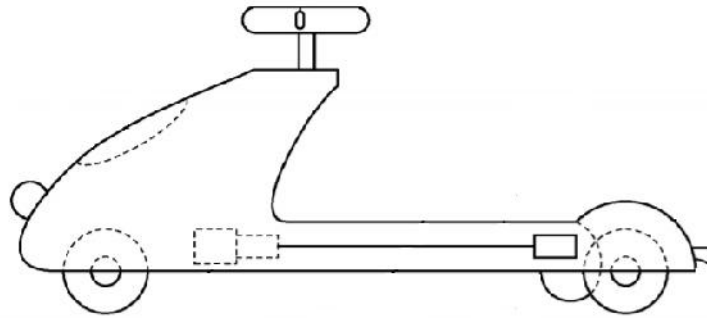

427

428 **Figure 34: Baby stroller invented by Perry [97].**

429

430 ii) Susan Gopaul invented baby stroller shown in Figure 35 with basic features  
431 yet multifunctional. The seat can be facing in a downward or sleeping  
432 position for the child. It can be placed so that the baby can see the front view  
433 or the be seated to see the rear view[98].



434

435 **Figure 35: Baby stroller invented by Gopaul [98].**

436

437       iii)     This collapsible baby carriage as shown in Figure 36 was invented by Qiang  
438               Zhang. It includes a pair of middle pushing rod, a pair of upper pushing rod,  
439               a pair of T-rod, a pair of front wheel rod, a pair of bending-extension rod, a  
440               pair of side sliding rod, a pair of handles and a pair of seat side bending rod  
441               at two sides thereof. The baby carriage includes a folding mechanism. The  
442               folding mechanism turns the upper pushing rod upward and the middle  
443               pushing rod and the front wheel rod downward. The flipping mechanism  
444               flips the seat side bending rods, the bending-extension rods, the front wheel  
445               rods, the front wheels, the handles, the T- rods and the rear wheels inward,  
446               forming a flat and rectangular body [99–103].  
447

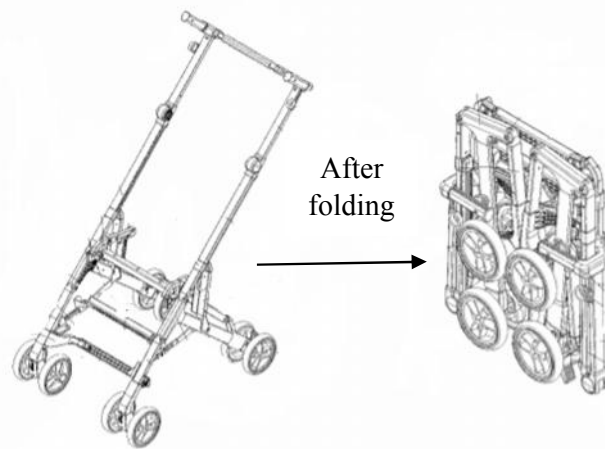

448  
449  
450

**Figure 36: Baby stroller invented by Qiang Zhang [99].**

451     Year 2018

452

453       i)     Child stroller in Figure 37 was invented by Kori Faith Duboff and Kimberly  
454               Mar Alicea. It includes a frame, a plurality of wheels, a child-seat assembly  
455               configured to rock back-and-forth with respect to the frame; a rocker  
456               assembly secured to the child-seat assembly. The rocker assembly includes  
457               a plurality of legs, each leg defining an undersurface, each undersurface  
458               being arced a rocker base, the rocker base comprises an inner surface. The  
459               stroller is configured such that when the child-seat assembly rocks  
460               back-and-forth with respect to the frame, the legs rock back-and-forth upon  
461               the inner surface of the rocker base[104].

462



463

464

**Figure 37: Baby stroller invented by Qiang Zhang [104].**

465

- ii) This convertible baby stroller in Figure 38 was invented by Christy Hanson, Robert R. Roberts, Sienkiewicz, Travis Yoch, and Peter Young. A design that is rather unique because this baby stroller can be worn around the user's waist with a pulling rail that can attach to an adjustable running belt. An adjustable stroller having a main carriage and a handle bar assembly that is configured to allow the user to push or pull the stroller. A third front wheel is built for stability and balance reciprocating the two rear wheels attached to the main carriage. Furthermore, the adjustable stroller more specifically includes main carriage, pulling rails comprised of handle bar tubes and telescoping rail tubes, three wheels, a crossbar and a centre handle [105–108].

466

467

468

469

470

471

472

473

474

475

476

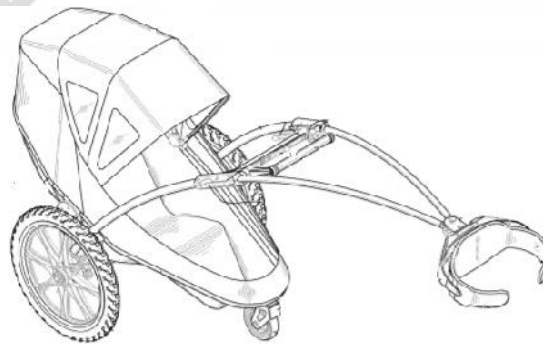

477

478

**Figure 38: Baby stroller invented by Hanson, Roberts, Sienkiewicz, Yoch, and Young [105].**

479

480

481       iii)    Baby stroller in Figure 39 was invented by Manuel Abreu with the intention  
482           to control the temperature of the baby stroller from hot and cold weathers.  
483           This stroller is built with a frame, a seat on the frame for the child and a  
484           temperature controllable element which is adjacent to the seat. The  
485           temperature controllable element controls the temperature of an  
486           environment of the child. It provides plenty storage at the bottom of the  
487           stroller. The heating and cooling element is a continuous hollow tube for  
488           transferring air, liquid or gas [109].

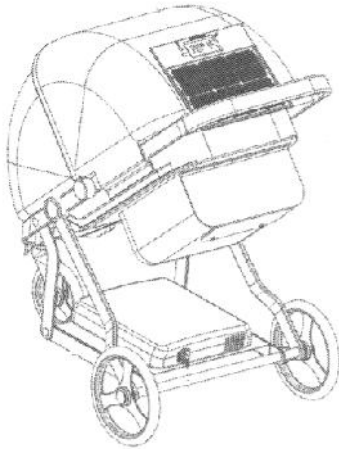

489

490



**Figure 39: Baby stroller invented by Abreu [109].**

### **3. Summary of patent review**



From the patent review of the year 2008 to 2018, there are a few characteristics and points that can be summarized on the design of baby strollers throughout these years. Some of the basic features and mechanism that is obvious on baby strollers are: canopy, foldable mechanism, ergonomic design and ample storage space. Next, improvements can be seen on the baby stroller as the year's increases is summarized in Table 1 respectively.

UNDER PEER REVIEW

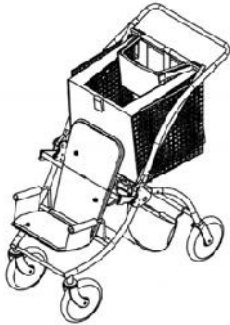
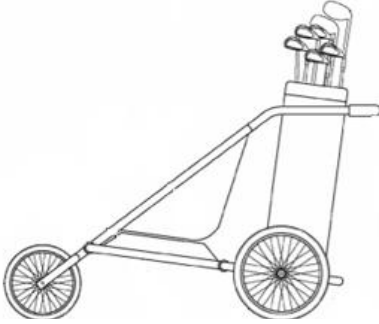
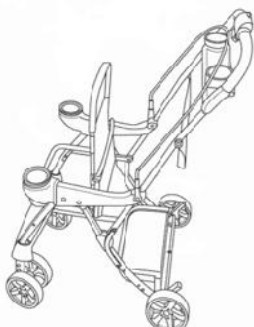

**Table 1: New implementation and improvements made on baby strollers**

No	Implementation	Patent	Remarks
1.	Multipurpose Functions: Extra seating space	 <p data-bbox="781 726 902 753">Year: 2009</p> <p data-bbox="662 783 1024 842">Inventor: Marie Schutzendorf and Corbett Griffith</p>	An optional removable side seat for a baby stroller, to seat a second child. The side seat can be folded neatly and compactly.
2.	Multipurpose Functions: Stand and sit (2 in 1)	 <p data-bbox="781 1257 902 1285">Year: 2010</p> <p data-bbox="670 1314 1016 1373">Inventor: Wes Thomas, Toriono Granger, James Morrow</p>	A foot platform attached to allow the child to stand.
3.	Lights	 <p data-bbox="781 1734 902 1761">Year: 2011</p> <p data-bbox="719 1791 967 1818">Inventor: Gerald Gross</p>	LED as embedded lights, forward and rear light source attached onto baby stroller.

**Table 1 (cond't): New implementation and improvements made on baby strollers**

No	Implementation	Patent	Remarks
4.	Multipurpose Function: Storage	 <p data-bbox="781 726 902 751">Year: 2012</p> <p data-bbox="721 779 963 804">Inventor: Harri Ektron</p>	Baby stroller includes and expandable shopping cart.
5.	Multipurpose Function: Storage	 <p data-bbox="781 1224 902 1249">Year: 2012</p> <p data-bbox="688 1276 998 1302">Inventor: Jean-Pierre Joubert</p>	An athletic accessory container was built into the baby stroller.
6.	Automatic controller	 <p data-bbox="781 1722 902 1747">Year: 2012</p> <p data-bbox="688 1774 995 1799">Inventor: Chih-Hsiung Yang</p>	An automatically controllable smart stroller which includes a body-movement detecting unit, a drive control unit and a drive unit.

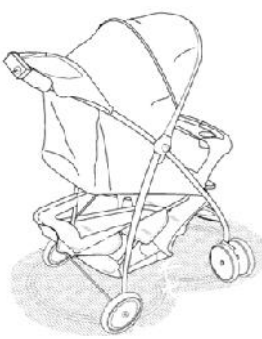

**Table 1 (cond't): New implementation and improvements made on baby strollers**

No	Implementation	Patent	Remarks
7.	Multipurpose Functions: Stand and sit (2 in 1)	 <p data-bbox="781 726 902 758">Year: 2014</p> <p data-bbox="651 779 1032 810">Inventor: Bradley James Mattarocci</p>	A platform positioned rearward of the forward-facing seat to allow a child to stand on it.
8.	Multipurpose Functions: Changing table unit	 <p data-bbox="781 1220 902 1251">Year: 2015</p> <p data-bbox="626 1272 1057 1304">Inventor: Daniel and Magdalini Penello</p>	Baby stroller includes connectors for connecting the baby-changing table unit which includes a diaper receiver and a handy-wipe receiver
9.	Lights	 <p data-bbox="781 1724 902 1755">Year: 2015</p> <p data-bbox="724 1776 959 1808">Inventor: Sean Gilbert</p>	Incorporates a lighting system that compromises a fastenable light strip. On active mode, the ground beneath the baby stroller is illuminated.

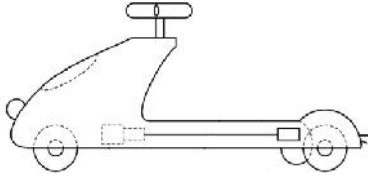
**Table 1 (cond't): New implementation and improvements made on baby strollers**

No	Implementation	Patent	Remarks
10.	Multipurpose Functions: Stand and sit (2 in 1)	 <p data-bbox="781 726 902 753">Year: 2016</p> <p data-bbox="613 783 1070 842">Inventor: Patrick Laffan, Leslie Stiba, Hao Tian</p>	The base of the frame is expanded backwards to create more storage space behind the baby seat, allowing the child to stand on it.
11.	Motorized	 <p data-bbox="781 1125 902 1152">Year: 2017</p> <p data-bbox="716 1178 967 1205">Inventor: Corban Perry</p>	Equipped with a motor to operate the baby stroller.

1 **Table 1 (cond't): New implementation and improvements made on baby strollers**

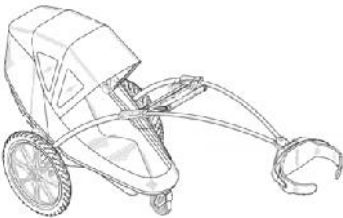
No	Implementation	Patent	Remarks
12.	Multipurpose Function: Rocking Mechanism		<p>A rocker assembly secured to the child-seat assembly. The child-seat assembly rocks back-and-forth with respect to the frame</p>
		Year: 2018	
		Inventor: Kori Faith Duboff and Kimberly Mar Alicea	
13.	Temperature controllable elements		<p>A temperature controllable element which is adjacent to the seat was implemented. The heating and cooling element is a continuous hollow tube for transferring air, liquid or gas</p>
		Year: 2018	
		Inventor: Manuel Abreu	
14.	Modern design		<p>A rather unique bay stroller design that can be considered as state-of-the-art design.</p>
		Year: 2018	
		Inventor: Christy Hanson, Robert R.Roberts, Sienkiewicz, Travis Yoch, Peter Young	

## 2 **4. Survey on preferred strollers in Malaysia**

3 Baby stroller has all the basic features that parents know of as stated in the section  
4 above. It can be summarized that the preferred baby strollers have characteristics like  
5 lightweight, multi-functional, ample storage, cup holders, safety features and  
6 importantly features that prioritized their child's comfort. A further research has been  
7 done as shown in Table 1 that focuses on baby stroller customers in Malaysia. This  
8 particular research is done to understand and learn in depth of parents' choice and  
9 preference on baby stroller. The source of research will be based on online shopping  
10 websites that are visited frequently by Malaysian customers.

11

12 Table 1 as shown below is based on its popularity by customers in online shopping  
13 websites targeted in Malaysia. The baby stroller popularity is rated according to the  
14 number of stars, five stars being the highest. According to research, parents prefer  
15 strollers that have safety features, easy to store it anywhere, storage, canopy availability,  
16 and new-born ready. This can be proven by referencing to Table, as the baby strollers  
17 that are popular in online shopping websites fulfilled said criteria. This helps us to  
18 know what the focusing points when inventing or applying innovations to baby strollers.  
19 A few baby strollers, for example, baby stroller brand Sweet Heart Paris ST230 serves a  
20 multi-functional purpose, such as it can be used as a rocking chair. As the generation is  
21 evolving, new innovations and technological mechanism can be introduced to attract  
22 parents and baby stroller users.

23 **Table 2 : Popular baby strollers in online shopping website, Lazada and Shopee.**

Brand	Rating (1-5 stars)	Features
 <p data-bbox="311 594 613 619">OSH 5 Wheels Magic Stroller</p>	5	Foldable, adjustable aluminium alloy, regulating pedal, comfortable seat, Weight: 3.2kg
 <p data-bbox="386 963 539 987">GB Pockit Plus</p>	5	Smart and ultra-compact folding, 5-position harness system, adjustable seatback, storage and canopy availability, self-standing when folded, one-hand push, Weight: 5.6kg
 <p data-bbox="386 1356 539 1379">Joie Pact Cabin</p>	5	Compact fold, full-size canopy with eyeshade visor, UPF 50+ sun canopy, multi-position recline for backrest, full-size storage, 5-point harness, wheel suspensions, Weight: 6kg

24

25

Remark: 1 star implies least popular; 5 stars implies most popular

26

Source: Online shopping platform- LAZADA website; Shopee website; Keywords used: baby strollers, designs, popular

27

28  
29

**Table 2 (cond't): Popular baby strollers in online shopping website, Lazada and Shopee.**

Brand	Rating (1-5 stars)	Features
 Little One 2 in 1	5	Foldable, tray with cup holder, large storage, additional baby car seat, one-hand folding system, lockable front swivel wheel, reclining seat, canopy availability with window, 5-point harness
 AMGO Detachable T1508	5	Foldable, shock absorption system, multiple reclining positions, canopy and storage availability, sun-proof fabric, top grade single-foot brake system, adjustable handle height, non-slip grip, 5-point harness
 Sweet Heart Paris ST230	4	Foldable, rocking mechanism, three-position backrest adjustments, washable and comfortable seat, adjustable handle, brakes availability, 3-tier canopy with mosquito net, Weight: 7.3kg
 ECOBEE	4	Foldable, multiple position seat recline, 5-point safety harness, lockable front swivel wheels, rear wheel suspensions, storage and all-weather adjustable canopy availability, brake availability, ultra-light, Weight: 3.8kg

30  
31  
32  
33

Remark: 1 star implies least popular; 5 stars implies most popular

Source: Online shopping platform- LAZADA website; Shopee website; Keywords used: baby strollers, designs, popular

34 Next, research has been done to recognize what are the popular baby stroller brands  
35 in our targeted location, Malaysia. As a buyer, a recommended brand is always  
36 reassuring because users will know if it's the right or close to the perfect choice for  
37 other users. Good brands that are highly recommended should be able to fulfil parent's  
38 needs in everything they hoped for in a baby stroller.

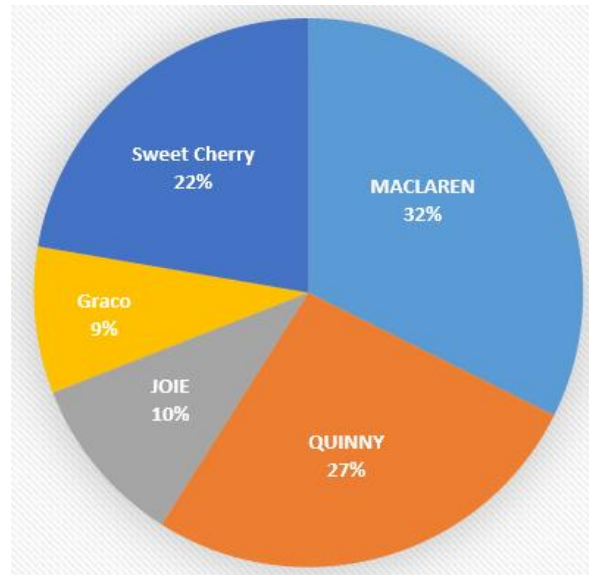

39  
40 *Source: Google Search Engine Keywords used: baby stroller, recommended, popular, Malaysia*

41 **Figure 40: Popular baby stroller brands in Malaysia.**

42  
43 Chart presented in Figure 40 are the few shortlisted brands that are popular in  
44 Malaysia. These trendy and highly recommended brands lean a little towards the pricier  
45 cost compared to the baby strollers on online shopping websites such as Shopee and  
46 Lazada. Nevertheless, of its price, it is still a popular choice among users in Malaysia.  
47 These baby stroller brands are referenced from various shopping websites where baby  
48 stroller can be purchased according to its brands. Top in the recommended list would be  
49 baby stroller brand Maclaren as it is the most suggested brands in Malaysia[111].  
50 Maclaren was founded since 1967 and it's still a popular choice due to their variety of  
51 baby stroller selections. Maclaren products are customized for a variety of lifestyles,  
52 fashions, trends, and are proud of their safety and durability of baby strollers. Quinny is  
53 another brand to look forward to as it is a rather popular choice of baby stroller users.  
54 Quinny offers a variety of baby strollers that also serve multipurpose functions with its  
55 accessories. Other brands like Sweet Cherry, Joie and Graco as mentioned in the chart

56 are also top choices among Malaysian users. Ergonomic designs and functions are the  
57 primary implications in these baby stroller brands.

58 To summarize this section, baby strollers with easy to like designs that must have  
59 basic features like canopy, storage, safety features and multipurpose functions are the  
60 most common choice among users. When inventing or making improvements, these  
61 baby stroller features must be taken into considerations to create an ergonomic baby  
62 stroller. In addition, since technical features and trendy items are still less implemented,  
63 it is recommended to consider such features to be added into baby stroller designs and  
64 applications.

65

## 66 **5. Future Research**

67 Baby stroller design is still a topic of interest, and as an engineer, it is in our  
68 profession to look for ways to improve and innovate. There are still functions and  
69 potential ways to improve the design of existing baby strollers.

70 Baby stroller wheels are the base that maintains the stability of its chassis. An idea  
71 to combine present invention that are rather popular among generation today may be  
72 implemented. This invention can be served as wheels for the baby stroller and later be  
73 detached to be functioned as another purpose[66][112]. Safety features are needed as  
74 the wheels are crucial parts of the baby stroller. An easy locking system that can be  
75 controlled with a single part of the body to cater users especially ones with backache  
76 issues and usually pregnant ladies. Wheels that are not too tight yet safe to be  
77 manoeuvred with one hand, so users can multitask with the other hand. For tyres, shock  
78 absorber makes the bumpy ride to a smooth sailing and reduces vibrations acting on the  
79 baby and a user's hands.

80 Baby stroller users are usually in different heights. An adjustable height  
81 mechanism that users are familiar with, for example, mechanism that can be seen on  
82 suitcases are to be implemented. Two kinds of handles may be enforced to ensure ease  
83 to users when they are given a situation where either one hand or two hands are to be on  
84 the baby stroller. Baby strollers should also be favourable for users. As seen in existing  
85 strollers, cup holders serve a good purpose. So, there will be improvements done on  
86 these cup holders.

87 The canopy is essential on baby strollers as they serve multiple purpose. Living in a  
88 tropical country, mosquitoes are very threatening. Existing baby strollers provide  
89 mosquito nets, but it is needed to be carried separately. The idea to combine the net to  
90 prevent from having the trouble to carry it separately or ends up forgetting to bring the  
91 mosquito net. A better viewing area can be done so that baby stroller users could look  
92 from behind at their child while pushing the stroller.

93 Fabrics to be used may be baby proof friendly to lessen the hassle of having to  
94 clean and washing it up frequently. It can be cooling and non-heat absorbent for the  
95 comfort of the baby and the user. Material for baby stroller handles may be heat  
96 resistant and capable of absorbing moisture, sweat and provides good gripping for the  
97 user.

98 Existing baby strollers have some lacking on electrically operated and necessary  
99 features. Multiple attachments can be implemented on baby strollers for fulfilling an  
100 ergonomic design and serve many positive purposes. Improvements can be made to  
101 these attachments, for example, adding more kind of attachments and having  
102 everything fixed in one solid attachment. The attachments should serve good and legit  
103 functions for the baby and the user. The new potential attachments can cater to the  
104 needs of babies by making them comfortable on hot weathers and allow the users to  
105 navigate baby strollers in a poor lighting area. Attachments may also entertain the baby  
106 much easier[113][35].

107 The seat is another crucial part of a baby stroller. There are many potential  
108 possibilities to improve the seat and seating area for the baby's comfort. The seats may  
109 be well ventilated and heated as per user's request for baby's convenience. Extra  
110 spacious compartments may be added in this area and the design of the baby seat should  
111 be able to support the baby's backbone. The seat may also have multiple positions that  
112 can be adjusted and incorporate the element of attachability for further purpose[110].

113 Safety features of this improved baby stroller shall meet parents' satisfactions.  
114 Shielding will be an important element in this category. Extra cushioning is necessary  
115 to protect the baby or child's fragile figure. Five-point harness system will be used  
116 because that is the best safety belts to prevent babies from falling or tripping. A  
117 mechanical device may be added to prevent bumpy rides and reduce vibrations acting  
118 on the baby and a user's hands.

119 It is important to know that there is always room for improvements and right ideas  
120 to achieve a new purpose of an invention. With the world moving forward to an era of  
121 smart technology, we are bound to succumb to future needs. Future inventions should  
122 be able to fit in with the impending society and generation. Thus, there are always  
123 potential ways to modify existing inventions to accord for the future.



124  
125

126 **Figure 41: Proposed attachments on baby stroller for various application.**

127

128 The proposed attachments as presented in Figure 41 are a few of the attachments  
129 that are essential to a baby stroller. These attachments will benefit both the baby and  
130 user as it serves a practical purpose. The idea of combining four attachments into one  
131 whole attachment can be considered and implemented. By doing this, baby stroller  
132 users would not need to carry multiple attachments when they are in need of it. The  
133 attachments are modern and popular items used by society today especially the use of  
134 hover board.

135 **References**

- 136 [1] When was the baby stroller invented?, (2017).  
137 <https://www.quora.com/When-was-the-baby-stroller-invented>.
- 138 [2] phil&teds, The history of the stroller – from then to now, (2017).  
139 <https://philandteds.com/news/2017/07/history-stroller-now/>.
- 140 [3] Whattoexpect, History of Baby Stroller, (2017).
- 141 [4] Whattoexpect, MASS-PRODUCED STROLLERS, (2017).
- 142 [5] M. Bellis, History of Baby Carriage, (2017).
- 143 [6] Maclaren, First Umbrella Stroller, (1967).
- 144 [7] Baby Jogger, Baby Jogger, (1984).
- 145 [8] Mon Ami, Baby stroller in market, (2018).
- 146 [9] K. Wang, Foldable Baby Stroller, 2008.
- 147 [10] H.F.T.D.D.J. Koes, Stroller, US 20080211206A1, 2008.
- 148 [11] A. Wegner, Collapsible pram/pushchair frame, 1993.
- 149 [12] J. Feyler, Children’s carriage having a backrest that can be pivoted by an electric  
150 motor, 2003.
- 151 [13] L. Habib, Basket for stroller, US4346912A, 1979.
- 152 [14] K. Kassai, Seat assembly for baby carriages, US4435012A, 1981.
- 153 [15] A. Evron, Infants’ carriages, US4491335A, 1982.
- 154 [16] K. Kassai, Baby carriage, US4610460A, 1984.
- 155 [17] K. Kassai, Mechanism for locking the opened state of a baby carriage,  
156 US4542916A, 1983.
- 157 [18] K. Kassai, Baby carriage, US4626030A, 1985.
- 158 [19] K. Kassai, Baby carriage, US4317581A, 1980.
- 159 [20] K. Kassai, Mechanism for locking opened state of baby carriage, US4616844A,  
160 1984.
- 161 [21] R.T.P.D.S.S.S. Faktorovich, Stroller with child barrier and pivotable cup holder,  
162 US007571925B2, 2008.
- 163 [22] G. Storm, Stroller, USD615461S1, 2009.
- 164 [23] M.S. Griffith, Deployable side seat for a baby stroller, US8128103B1, 2009.
- 165 [24] L.G. Hobgood, Supplementary seat for motor-cycles, US1212221A, 1917.
- 166 [25] P.C. Hicks, Seating and controlling attachments for barber chairs, US2836224A,  
167 1954.
- 168 [26] P.M.T.G. Troup, Infant stroller, US20110095510A1, 2010.

- 169 [27] R. Cletus, Tandem two-seat stroller, US3309101A, 1965.
- 170 [28] S.-M.C.-R. ZHONG, Collapsible stroller, US20080238042A1, 2008.
- 171 [29] J.-Q. Li, Tandem stroller, US8602441B2, 2010.
- 172 [30] Iiik.J.W. Charles E. Wheeler, Carriage assembly, US4542915A, 1983.
- 173 [31] J.G. Longenecker, Stroller with travel seat attachment, US20100171289A1,  
174 2010.
- 175 [32] F. Reginald, Automatic brake mechanism for hand-propelled vehicles,  
176 US1709527A, 1927.
- 177 [33] H.W.S.T. Baumgartner, Collapsible stroller, US2783053A, 1956.
- 178 [34] W.T.G. Morrow, Sit or stand strollers and methods of making the same,  
179 US20100244393A1, 2010.
- 180 [35] G. Gross, Illuminable baby stroller, US20120155097A1, 2011.
- 181 [36] R.P. Stauffer, Stroller with programmable information module,  
182 US20030132612A1, 2003.
- 183 [37] F.Y.F.M.P. Dodman, Intrinsically illuminated tubular member of a bicycle and  
184 bicycle having same, US20120051072A1, 2011.
- 185 [38] S. Gilbert, Baby stroller lighting system, US 2016.0009219A1, 2015.
- 186 [39] J.A. Thomas, Illuminated Rigid Body Using Contiguously Illuminated Light  
187 Source, US20080266833A1, 2008.
- 188 [40] C.-I. Lai, Baby carriage, US20120292888A1, 2011.
- 189 [41] K. Kassai, Baby carriage, US4191397A, 1978.
- 190 [42] K. Kassai, Collapsible baby carriage, US4272100A, 1979.
- 191 [43] H. Ektron, Combined shopping trolley baby stroller, US20140232088A1, 2012.
- 192 [44] S.G. Brottman, Shopping cart, US2615726A, 1947.
- 193 [45] J.R.S. Michels, Stroller convertible to walker and carriage, US3079162A, 1961.
- 194 [46] L.G. Bell, Foldable cart, US4765644A, 1987.
- 195 [47] L. Stiba, Stroller and shopping cart, US8070180B2, 2008.
- 196 [48] J.-P. Joubert, Infant stroller with athletic accessory container,  
197 US20120319371A1, 2012.
- 198 [49] H.O. England, Golf carts, US3291502A, 1966.
- 199 [50] H.A. John, Golf club carrier in the form of a trolley, US3360279A, 1967.
- 200 [51] J.K. Fontenot, Combined golf bag and cooler cart, US5193842A, 1992.
- 201 [52] C.-H. Yang, Automatically Controllable Smart Stroller or Wheelchair,  
202 US20130162396A1, 2012.
- 203 [53] G.J. Felling, Chaise lounge with motor-driven adjustable canopy, US5069504A,

204 1990.

205 [54] H. Richmond, Vehicular security system with remote signalling for auto  
206 carjacking functions, US5382948A, 1993.

207 [55] P.Z.A. Nyberg, Wheelchair power system, US5495904A, 1994.

208 [56] D.K.L.M. Lim, Wheelchair control sensor using movement of shoulders and  
209 wheelchair drive control apparatus using the same, US20040216943A1, 2003.

210 [57] M. Zehfuss, Baby stroller, US20130113185A1, 2012.

211 [58] K. Kassai, Baby carriage, US4846494A, 1988.

212 [59] S.A.S. von Flotow, Collapsible baby stroller and releasable locking and folding  
213 mechanism therefor, US6102431A, 1998.

214 [60] R. Glover, Stroller latch apparatus, US6422586B1, 1999.

215 [61] C.-F.Y.-T.C.-P.H.-P. Chou, Convertible tandem stroller frame,  
216 US20130234419A1, 2013.

217 [62] D.M. Gondobintoro, Expandable stroller, US6676140B1, 2002.

218 [63] J. Kinzel, Transport trolley, US20040169353A1, 2002.

219 [64] R. Powers, Child-scalable stroller, US20060290107A1, 2005.

220 [65] Y.-Z.C.-L. Mo, Stroller, US8480115B2, 2009.

221 [66] B.J. Mattarocci, Stroller, US20150001821A1, 2014.

222 [67] L. Shamie, Tandem stroller, US4725071A, 1987.

223 [68] M. Haung, Stroller with double seats, US5664795A, 1995.

224 [69] C.-H. Yang, Multi-seat stroller, US6086087A, 1999.

225 [70] L. Storch, Safety device automatically helps prevent runaway baby strollers,  
226 US20140225340A1, 2014.

227 [71] E.S. Alt, Toy vehicle, US2289331A, 1942.

228 [72] V.A. East, Child's vehicle, US2616725A, 1952.

229 [73] R.H.N. Foster, Packaging for umbrella strollers, US9517790B2, 2014.

230 [74] A.C. Risdon, Envelopes, US2979189A, 1958.

231 [75] D.L. Cospers, A support for storing and shipping small boats, US4016976A,  
232 1976.

233 [76] T.E. Deaton, Dust mop package, US5566820A, 1995.

234 [77] S. Gilbert, Baby stroller lighting system, US20160009219A1, 2015.

235 [78] D.P. Penello, Portable baby-changing table apparatus attachable to a baby  
236 stroller, US9924806B2, 2015.

237 [79] C.B. Kim, Multi-function baby support and transport apparatus, US5234224A,  
238 1991.

- 239 [80] T.E.M.C. Arnold, Stroller accessory bar and drink holder, US5464183A, 1993.
- 240 [81] R. Grantz, Stroller with fold out changing table, US8480114B1, 2011.
- 241 [82] T.M.P.R.B.T.Y. TONG, Access optimized child support device,  
242 US20160192787A1, 2016.
- 243 [83] C.P.L.Santosj.H.E.Bartzl.Dudkowskis.M.Maddoxm.C. WANG, Convertible  
244 jogging and all-terrain strollers, US9481389B2, 2015.
- 245 [84] D.B. Miller, Stroller, US20020041083A1, 2001.
- 246 [85] S.-L. Liu, Front fork swivel control structure of a jogging stroller Abstract,  
247 US7083175B1, 2005.
- 248 [86] T.-Y. Liao, Baby strollers, US9849902B1, 2017.
- 249 [87] T. Wang, Trolley frame foldable in one-step operation, US5558357A, 1995.
- 250 [88] L. Ageneau, Child stroller with umbrella type folding, US20060214395A1,  
251 2006.
- 252 [89] M. Golias, Collapsible supporting structure, US20060267303A1, 2006.
- 253 [90] T.-Y. Liao, Baby stroller, US9988064B2, 2016.
- 254 [91] M. Golias, Collapsible supporting structure, US7591479B2, 2003.
- 255 [92] G. Liao, Golf Bag Cart Foldable Device, US20100059948A1, 2008.
- 256 [93] P.W.L.S. Tian, Stroller with telescopic and locking members,  
257 US20140346756A1, 2014.
- 258 [94] D.W. Gill, Twosome walker-stroller, US2993702A, 1961.
- 259 [95] A.J. Browning, Suitcase attachment, US3257120A, 1966.
- 260 [96] H. Andersson, Telescopic guide, especially for transmittance of torque,  
261 US4705491A, 1986.
- 262 [97] C. Perry, Motorized baby stroller, US20180273118A1, 2017.
- 263 [98] S. Gopaul, Baby stroller, USD833918S1, 2017.
- 264 [99] Q. Zhang, Collapsible baby carriage, US9834243B1, 2017.
- 265 [100] J.P. Bosk, Collapsible child's carrier and seat, US2549958A, 1951.
- 266 [101] T.S. Lindabury, Collapsible stroller, US2429763A, 1947.
- 267 [102] W. Ernst, Collapsible baby carriage, US2170227A, 1939.
- 268 [103] D.D. Patterson, Baby strollers, US3365210A, 1968.
- 269 [104] K.F.D.M. Alicea, Child stroller with directional rocker, US20180346010A1,  
270 2018.
- 271 [105] C.H.R.R.A.S.E.Y.M. Young, Convertible stroller, USD825400S1, 2018.
- 272 [106] R.C. Everett, Infant jogging stroller, USD463762S1, 2002.

273 [107] S.W. Leu, Collapsible frame assembly and stroller, US5364119A, 1993.  
274 [108] R.C. Everett, Collapsible baby stroller for a jogger, USD419113S, 1999.  
275 [109] M. Abreu, Temperature-Controlled Stroller, US20180236913A1, 2018.  
276 [110] U.N. Sehat, A.R., State of the art baby strollers: Design review and the  
277 innovations of an ergonomic baby stroller, (2017) 55.  
278 [111] MAMOURS, Stroller, (n.d).  
279 <http://www.mamours.com.my/catalog/stroller-malaysia>.  
280 [112] J.S.H.T.W.P.L.M.S. Weiss, Ride along board for baby stroller, US8714582B2,  
281 2009.  
282 [113] C.-F.Y.-F. Yu, Attachment mechanism for stroller tray accessory,  
283 US6368006B1, 2011.  
284  
285

UNDER PEER REVIEW