

A Fuzzy Method For Meaningful Perspective on Visual Arts

Abstract

Following the previous works in the field of visual arts, I look at the development of perspective geometric rules, **in this paper**. A development based on fuzzy thinking and fuzzy geometry that can cover the rules of classical perspective and answer these classical perspective approaches that why the works created with the help of it lack refreshing and spirit. In this paper, introducing a meaningful perspective and geometric rules that include artist's personal independence, **I** try to open the way for creating flexible and mentally-oriented art works. It should be noted that one of the results of this paper is achieving a **method for meaningful** deformation in art.

Keywords: Fuzzy thinking, Fuzzy geometry, Geometric Perspective , Meaningful point, Meaningful line.

Introduction

Perspective is a science by which we show the distance and proximity of objects. Applying perspective rules, the development of three-dimensional objects in space can be made in the right way. The human eye acts like a tele-zoom lens camera. But the difference between the eyes and the camera is that the eye continuously captures images of the object. In addition, the visual nervous system of the viewer works in harmony with other senses and determines the scope of vision and clarity of the subjects. Condition of the eyes (which are constantly changing in different circumstances) are effective in visual understanding. Until the twentieth century, painters were struggling to display the physical reality of objects by precise drawing with the help of natural light-dark. But this kind of painting and drawing that only referred to the object and subject matter, could not really show the reality of the subject. Because the constant physical and mental states changes of man, as well as the various aspects of the subject from distant or near, upward and downward, and the other directions, reality of objects cannot be fully perceived. Therefore, such a drawing is only a representation of the false reality of the subject; it is not unreasonable that some artists in the early twentieth century revised the way they looked and painted and drew and introduced the new way of cubism. Of course, the oriental artists' method, especially the Iranian miniature painters, should be taken into account, and pay enough attention to their understanding of art, including the creation of objects in accordance with their nature and their beauty nature and contrasting with the false representation of objects[1,2]. **In the first half of the fifteenth century**, Brunelleschi was not only the initiator of the Renaissance architecture. He is attributed to the discovery of another renaissance in the field of art which had an impact on the art of the next century; this discovery was Perspective. It should be noted that even the Greeks, who knew the shortening of image components (to make it 3D), and Hellenistic painters who were proficient in deep induction, were unaware of mathematical and geometric rules based on which, the objects seem smaller when getting farther. It was Brunelleschi who gave the mathematical solution to the painters. Fig.1 shows one of the first paintings that is depicted based on these mathematical rules. This painting depicts trinity with Holy Mary and John the Apostle under the cross, and the donors - the elderly businessman and his wife – kneeling outside of the porch.

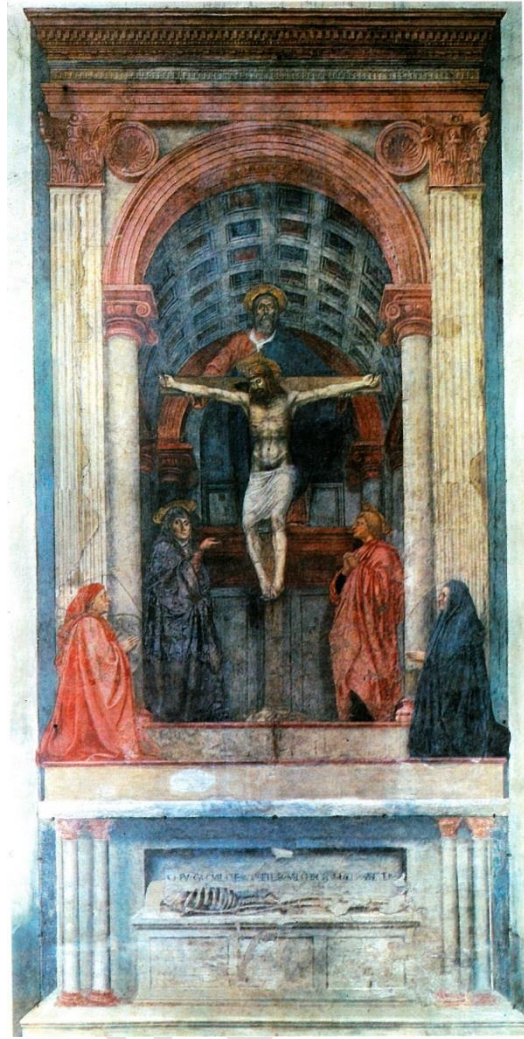

Fig.1. Masaccio.1425-1428.

We can guess that the people of Florence were so surprised when they first saw the wall paintings by Masaccio. The work created the illusion of a hole was created in the wall, through which they can look inside a Brunelleschi -type temple. After the Masaccio, and have to go a little further to reach another influential painter in the middle of the fifteenth century. Fig.2 shows an image of the birth of Christ depicted by Fra Angelico in one of the monastic cells. At first glance, the painter has been proficient in perspective. But undoubtedly Fra Angelico's intention was not to use optical illusion (like Masaccio) to induce the observer that a hole has been created in the wall. But his sole aim, such as Simone Martini, has been the most beautiful representation of the story.

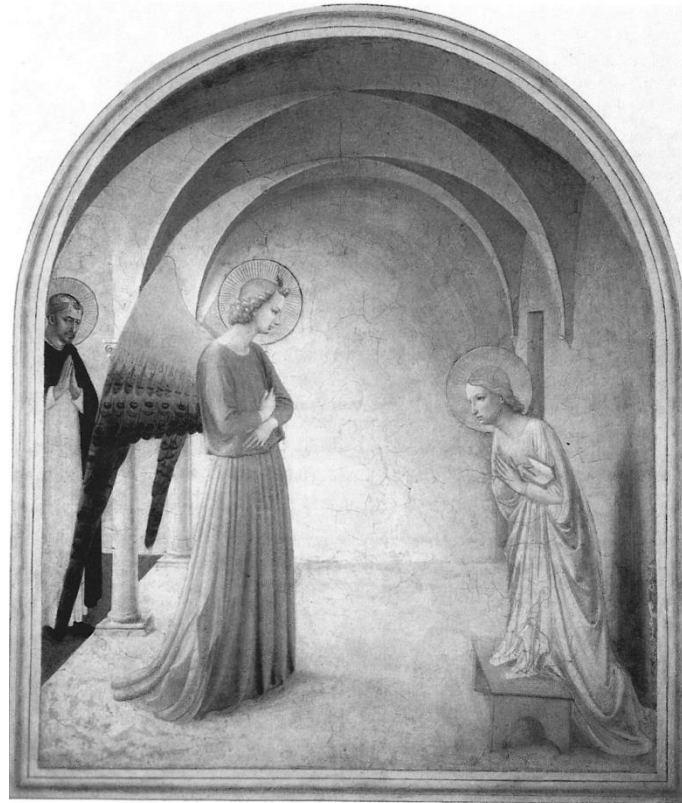

Fig.2. Fra Angelico.1440.

Notice that there is no so much mobility in Fra Angelico's picture, and it suggests less induction in representing true humans. However, it seems that his work has been amazing in his own way, reflecting the modesty of the great artist who, despite the profound understanding of the recent achievements of Brunelleschi and Masaccio in visual arts, has refused to display any modernity. We can see these achievements and the issue they bring in the work of another Florentine painter, Paolo Uccello. The Pan-Romano Battle picture (Fig.3) is another great works of the fifteenth century in terms of using perspective. But the important problem in this picture can be examined in the question of why the horses in this painting are more like wooden horses and why the entire picture depicts a puppet scene ?



Fig.3. Paolo Uccello.1450.

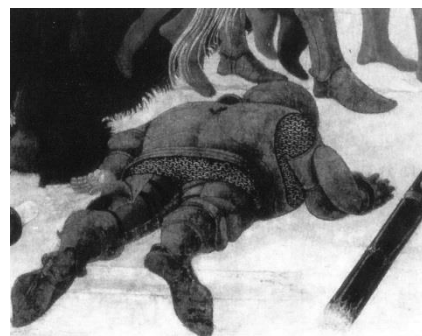

Fig.4. Part of the painting No3.

The reason is precisely that the painter has been so fascinated by his new art facilities that he was ready to do anything to make spatial prominence for his figures, as if they were carved and not painted. Perhaps his greatest **achievement** in this picture is the drawing of a warrior's figure who has fallen on the ground (Fig.4) whose perspective representation should be his hardest work in this picture. Such a figure had not been painted ever before, and although it looks much smaller than other figures, it can be guessed that a great excitement has been made. Everywhere in the picture, we can

find Uccello's interest in perspective and its magical attraction for him. Even the broken spears fallen on the ground have been decorated so that everyone is portrayed towards the common vanishing point. This regular geometric arrangement is the thing which later became one of the objections of the artists about artificiality of these scenes. A problem which, in particular, after the Renaissance period, led to a dramatic fading of application of perspective rules in the art of painting; this problem remains to this day.

Another influential artist in the application of perspective is Andrea Mantegna who lived at the same time as Masaccio. If we consider the work shown in Fig.5 called *St. James Led to His Execution*, we observe signs of the painter's efforts to apply the rules of perspective. But unlike Masaccio, he uses more perspective to create a scene in which his characters seem to be standing and moving like voluminous and tangible beings. But in the fifteenth century, and more specifically in the second half, the most prominent works in the use of perspective are the paintings of artists such as Piero della Francesca, like in *Constantine's Sleep*, around 1460(see Fig.6).



Fig.5.Andrea Mantegna.1455.

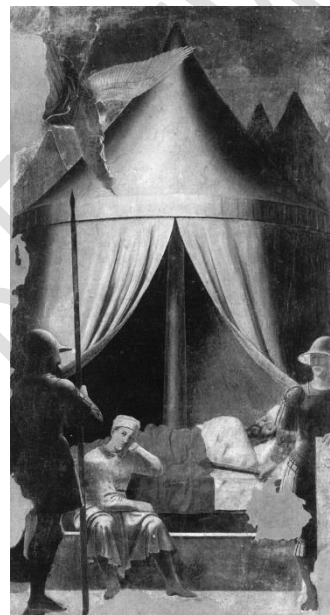

Fig.6. Piero della Francesca.1460.

The distinctive feature of Francesca's work compared to his former painters (even Masaccio) is that he added radiation of light to the geometric techniques of representation in the 3D space of the scene, which was as important as perspective. It can be said that nobody was able to with light as did della Francesca. The light in the above work, not only helps forming the figures' shapes, but also has the same importance of geometric techniques in the creation of depth induction for perspective. But all these did not reduce the problems of artificiality in perspective. The problems that exist even in the works of a painter like Antonio Pollaiuolo in fifteenth century; works such as the *San Sebastian Martyrdom* (Fig.7)[3,4].

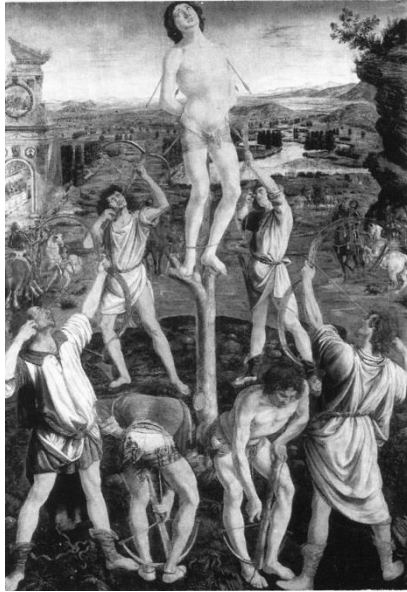

Fig.7. Antonio Pollaiuolo.1475.

In general, according to some historians, the evolution of perspective technique had been such that: they believe that the present perspective has been founded in the 15th century by the efforts of two great Italian painters Paolo Ucce and Piero della Francescas(Fig.8), and then Leonardo da Vinci evolved it. In the era when the Renaissance civilization began to replace the medieval civilization and scientific discoveries attracted the attention of the curious people, and the artists who advancing the development of civilization and culture welcomed this scientific advancement. From that time on, anyone who learned to paint, necessarily learned perspectives[5].

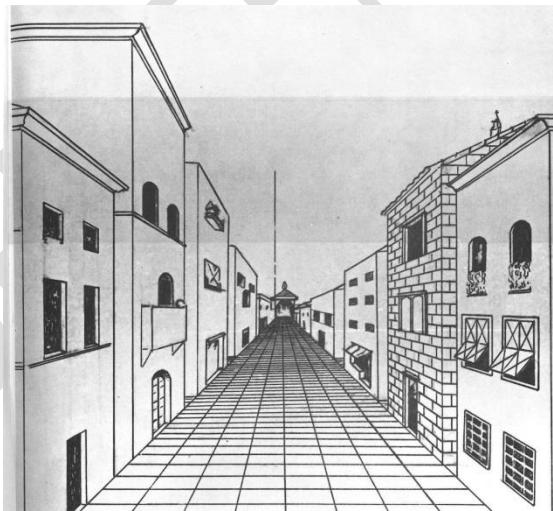

Fig.8. Piero della Francescas .Scientific perspectives. 15th century.

Perspective of the line and volume brought the perspective of color. The vivid colors of the medieval period went away from the painters' works, and were replaced by light-dark and depth (it should be noted that I do not focus our attention on the perspective of color in this paper). In this way, the art of painting and drawing found a new form in association with science. In fact, it gained something, but lost something important, and that was the instinctive perception of the artist of nature. Today, most art experts believe that the works of Giotto and Angelico, despite the inappropriate perspective (sensory perspective) and the lack of respect for the proper proportions (the relationship of images with the surrounding architecture), are more poetic than Piero della Francesca's works, and the seemingly scratches of Paul Klee or messy drawings of Van Gogh are more valuable than the

drawings of Courbet and David, because Klee and Van Gogh did not observe the scientific rules of the perspective[5].

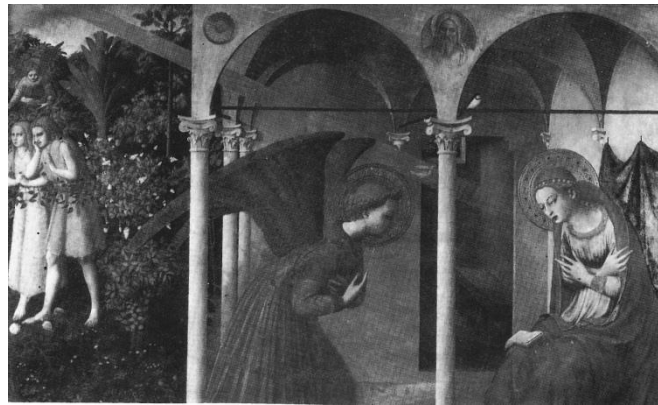

Fig.9. Angelico. 15th century.

Classical artists have changed the scientific rules and proportions of the organs of the body so that they do not seem false and not proportionate to prevent the appearance of obscene proportions (for example, in the perspective of body). The paintings of Explanation lesson by Rembrandt and Christ's body by Mantegna, fifteenth-century Italian artists, presents us striking examples of "sensory fit".



Fig.10. The painting of Christ's body.

In the painting of Christ's body(Fig.10), look at the overlap of forms from leg to head: the knees behind the foot sole, the thighs behind the knees, the pelvis behind the thighs, the chest and abdomen behind the pelvis, and neck and the head of Christ in the last part. The perspective of photography undoubtedly made the legs much larger, and the head which was placed at the end was much smaller than normal. There are no perspectives in this picture. The Mantegna have depicted the Christ's body organs in a true proportion, but the head of Christ, which is the turning point of this work, has been shown to be larger than normal.

Carving on wood, the work of Albert Durer, a German artist (fifteenth century), shows us the way of body perspective in that time (Fig.11). A glass checkered window is placed near the model. The painter put a checkered paper on the table away from the window, and draws what he sees on the paper in the boxes of the paper. In order to be able to always look at the glass from the same point, he looks at the glass through a hole. From this distance, the proportion of model organs will be normal. But if the painter moves forward and wants to draw the body directly into the boxes of the window, the legs that are in front will naturally find an exaggerated size, and the head and other organs of the body will be smaller and unbalanced.



Fig.11. Carving on wood, the work of Albert Durer.

Here it is worth pointing out that perspective is a European phenomenon that plays an important role in Western painting and drawing structure, but has not been used in Oriental art. The lack of perspectives in the Oriental Art tradition or the presence of sensory perspective (sometimes false perspective) which is more or less visible in the original Persian miniatures, is one of the Oriental art features.

In our earlier works [6,7,8,9], I presented philosophical-mathematical foundations to achieve meaningful geometry in the visual arts space. In this regard, I defined the meaningful point and line, and described the meaningful contour and deformation based on fuzzy thinking. Now, in this paper, based on the previous works, I present meaningful perspective rules. The rules that take into account the individual emotions, talents, and features of the artist (even physical errors that cause disturbances in observation) in the application of perspective. The advantages of our definitions in this paper are that they:

- a) include the rules of classical perspective (in its definitive state);
- b) are simple and understandable;
- c) are flexible and expandable to multiple person choices.

It should be noticed that one of the side results of this article is achieving a regular Kantian principle of individuality for deformation in art which can be useful in creating work as well as criticizing or producing teaching methods. It is expected that with these characteristics and other features that are inherent in fuzzy thinking and geometry, the works created with meaningful perspective will have a great deal of variation. Of course, it should be noted that the limitations of artistic tools and materials in the present will not enable us to provide the various aspects of the materials presented. But with the technological growth, I hope to have more results, especially in the emerging branches of visual arts.

1. Meaningful single-point perspective

In the classical single-point perspective, the top, bottom, and sides of the picture are parallel to the image view. The sides of the object are approaching and, if we continue the side lines, they will cut off each other at a point (vanishing point) located on the horizon line. This horizon line is actually the same level of viewer's sight [10,11]. In Fig.12, we have drawn a cube in a view having a classical perspective. I continued the sides to determine the vanishing point on the horizon line.

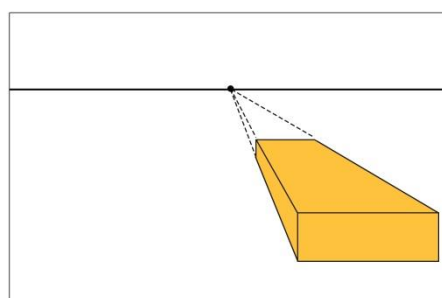

Fig.12. cube in single -point classical perspective.

Let's now consider the horizon line a meaningful line with respect to the artist's subjective meaning, and extend the vanishing point to the meaningful vanishing point (according to the definitions of the point and meaningful line presented in [6]). In this case, according to the artist's mental-behavioral meanings, he can choose any point of the set of meaningful vanishing points (with a degree of the function of meaning that represents the significance of the point), and connect the sides of the shape that wants to take to the perspective.

For example, consider Fig.13; in this figure, we have the line L as a meaningful horizon line and the point O as the meaningful vanishing point. As described in [6], the shape of the horizon line and the meaningful vanishing point depend on the corresponding meaningful function defined by the artist. This feature makes a great deal of diversity in perspective and actually personalizes the perspective.

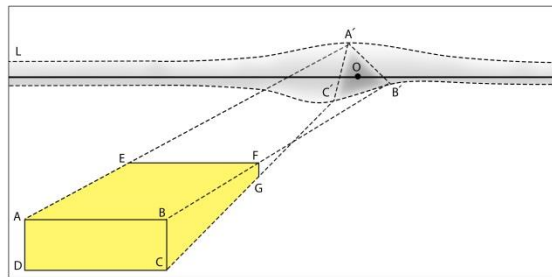

Fig.13.cube in single-point meaningful perspective.

To take our cube to the perspective, we have chosen the points A', B', C' in the triangular meaningful vanishing point, and have connected the vertices to them with dotted lines. In this way, a meaningful perspective is obtained, in which there is a deformed cube, which fully reflects the mentality and emotional-behavioral states of the artist. Here it is necessary to pay attention that the points A', B', C' depend on the artist's choices and they are chosen out of the infinite choices in the set of points within the triangle. If these points change, the shape of the cube's perspective and the kind of deformation will change.

Note: In a meaningful perspective, the artist is completely free to select the connect lines of AA', BB', CC' and even the lines of the sides of the cube i.e. AB, BC, CD, DA, EF as presented in paper [6] as meaningful lines with different values of meaningful function (less than one), which adds to the resulted shape deformation .To avoid the complexity of the discussion, we skip these states, and consider them to be lines with a value of meaningful function equal to one (the same crisp lines). It should be noted that in this type of perspective, the principle of the cube's faces parallelism is not necessarily retained, and it is even observed that in Fig.13, the face $BFGC$ has a deformed perspective that is influenced by the individual mentality and choices of the artist who created the work. This is the point of strength of meaningful perspectives, which involves the definite state in the usual perspective and also the necessary means for contemporary and modern artists to incorporate their mentalities into a personal frame.

2.Two-point meaningful perspective

Here, to draw a cube in a two-point meaningful perspective, we consider one horizon line and two meaningful vanishing points (as discussed above) and follow the steps below:

Step 1. First, determine one horizon line and two meaningful vanishing points whose shape depends on the artist's mentalities and the form of its meaningful function, like the meaningful horizon line and meaningful vanishing points in Fig.14. Then we draw a vertical line as the opposite side of the cube. In fact, it is the closest side to the viewer. (This line, which actually determines the length of the final cube height length, is also a meaningful line), Fig.14.

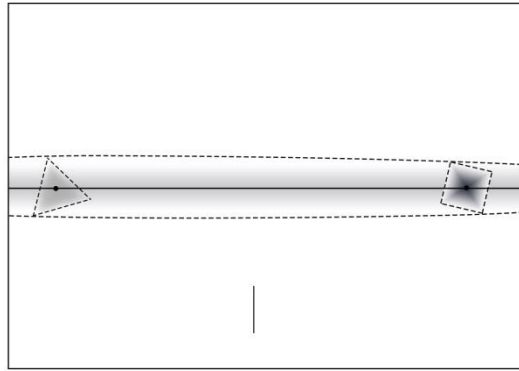

Fig.14. Sample for step1.

Step 2. To get the lateral faces of the cube, choose four points (which do not need to be distinct) from meaningful vanishing points. For example, in Fig15, in two meaningful vanishing points of O_1 and O_2 , we have chosen the points A, B, C, D among which the points of C, D are matched. These points depend entirely on the artist's choices and mentality in the final deformation of the cube. Now, we connect the points of the two ends of the line segment to these 4 points with meaningful lines, and two lateral faces of the cube are formed by drawing two vertical line segments.

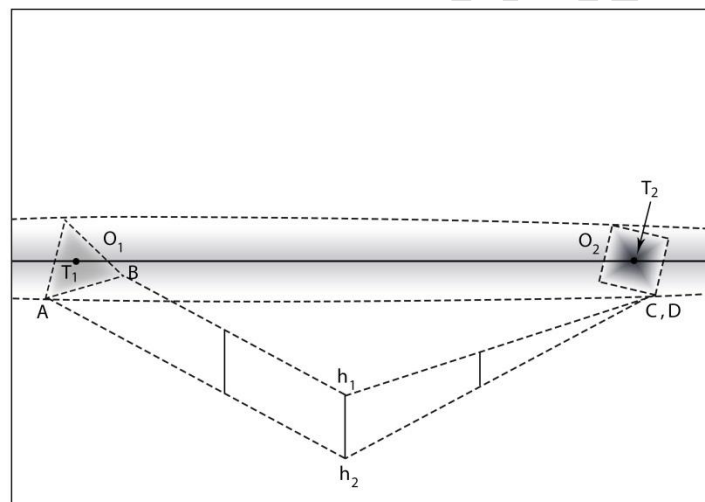

Fig.15. Shape of step2.

Note: If the points of A, B, C, D are chosen on points with degree of meaning function equal 1 i.e. T_1 and T_2 , then, we can use the definitive lines to have the same classical perspective.

Step 3. Consider some points of two meaningful vanishing points and connect them to the upper ends of the cube lateral faces to form the cube ceiling. In Fig.16, we have chosen the points E and F and connected the points S_1 and S_2 to them with two meaningful lines.

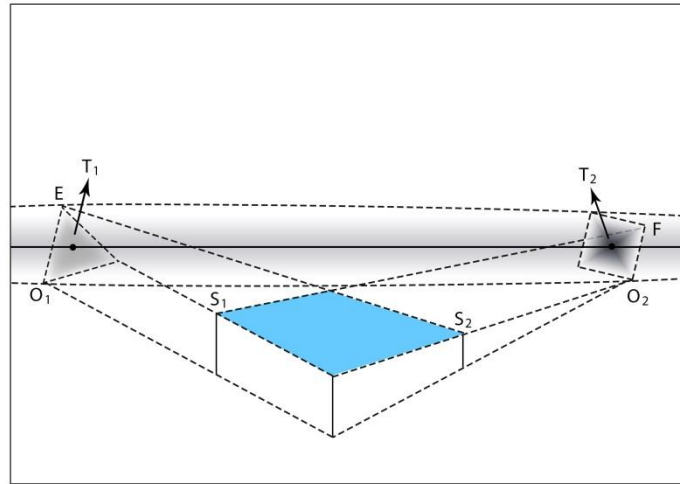

Fig.16. cube in two-point meaningful perspective.

As we can see, our choices have been such that the resulting cube has a kind of deformation in the perspective; this mode will be completely different with the changes in the points E and F or deformation of the meaningful lines making the cube's sides. The amount of this deformation is completely dependent on the mentally-behavioral choices of the artist and changes from one person to another. This feature is very useful in dealing with modern and contemporary art. To compare the amount of changes and deformation, we have presented a cube with classical perspective in Fig.17.

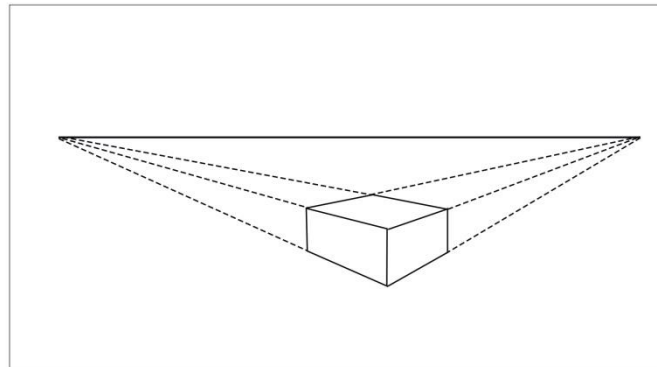

Fig.17. Cube in two-point classical perspective.

3.Ovals in meaningful perspective

It can be said that the cylinders are circles drawn in a perspective space. Cylinders alongside the cube are one of the most important shapes for composition in the artwork. They can be developed into cylinders and used to draw a variety of shapes. In the following, we present the meaningful single- and two-point perspectives for cylinders.

A. Single-point mode

Consider an oval that is drawn by a cube with a meaningful single-point perspective. The center of the oval is found by connecting the opposite corners of the quadrilateral shape inscribing the oval. Now, draw a vertical line on the central point. In this way, the oval is divided into two halves. To form a cylinder, draw another oval on the other side of the cube and connect them by a line segment. For example, consider Fig18. It is seen in the created cube that two lateral faces of S_1 and S_2 have a different slope to each other, and this results in a cylinder having imparallel upper and lower levels. In fact, meaningful perspective has produced a kind of deformation and curvature in the cylinder. If we

compare it to Fig.19 which represents a cylinder with classical perspective, this deformation can be easily seen.

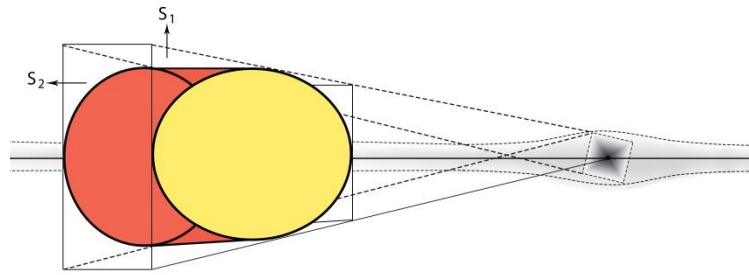

Fig.18. Cylinder in single-point meaningful perspective.

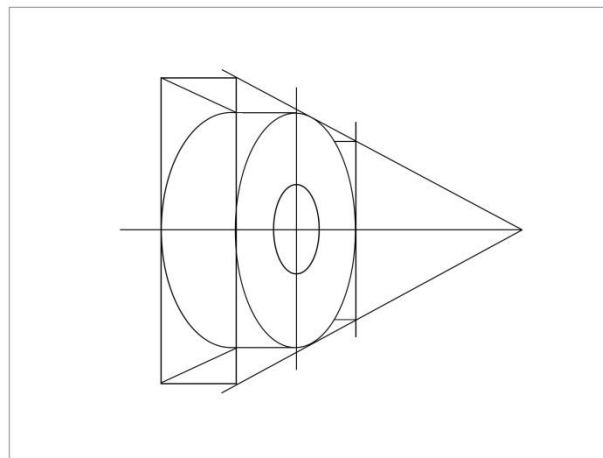

Fig.19. Cylinder in single-point classical perspective.

B. Two-point mode

In order to draw a cylinder in a meaningful two-point perspective, we first draw the upper part of the cube by a meaningful two-point perspective. We then round the corners to form an oval. If we want to turn it into a cylinder, we will make it high and complete the shape. For this, we stretch the upper and lower parts of the cylinder and connect the sides with a vertical line. For example, a cylinder in a meaningful two-point perspective is plotted in Fig.20.

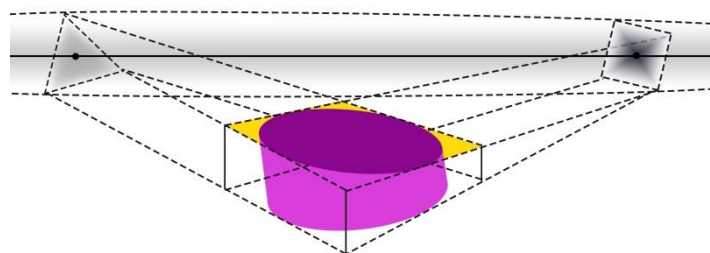

Fig.20. Cylinder in two-point meaningful perspective.

It can be seen that due to the difference in slope between the upper and lower faces of the cube in the meaningful perspective, the cross-section of the resulting cylinder has a kind of deformation which is clearly seen compared to Fig.21, which shows the cylinder in the classical perspective.

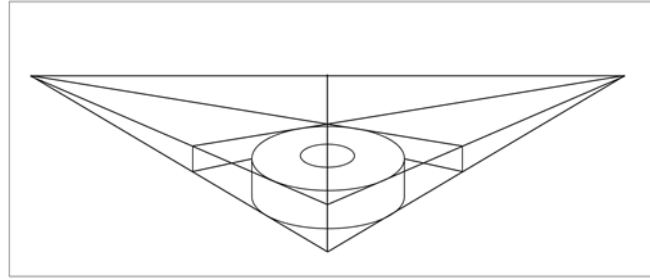

Fig.21. Cylinder in two-point classical perspective.

4. Meaningful three-point perspective

In the meaningful three-point perspective, two meaningful vanishing points are located the meaningful horizon line, but the third meaningful vanishing point is located somewhere in the upper or lower part of the meaningful horizon line. Below are the steps of drawing this kind of perspective.

Step 1. Draw a cube with the help of meaningful two-point perspective so that the meaningful horizon line is placed in it, like Fig.22.

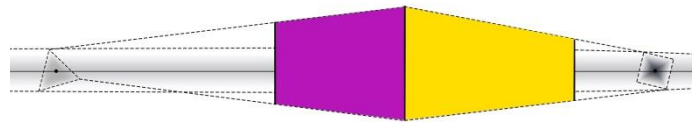

Fig.22. Shape of the first step.

Step 2. Connect the corners of the smaller side to each other. The intersection point of these two lines gives the base of the third vanishing point. Draw a vertical line to indicate the height of the ceiling.

Step 3. Place your ruler on the front and upper corners of the cube so that it cuts the vertical line. After cutting, continue the vertical line. The third vanishing point is somewhere along this line. Then, draw a line from this point to top and back corner of the cube to form the back angle of the ceiling. Now draw a vertical line from the meaningful vanishing point 2 to the intersection of the initial line of the meaningful vanishing point 3. This will complete one side of the ceiling.

Step 4. To complete the ceiling, draw a line from the topmost point of the ceiling to the top left corner of the left view. The shape is now complete.

The steps 2-4 are shown in Fig.23. It should be noted that in this figure, deforming the meaningful horizon line or meaningful vanishing points, the resulting deformation in the shape resulting from the three-point perspective will also be changed.

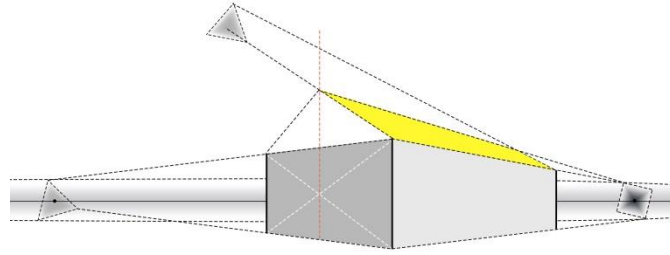

Fig.23. Shape of a home in three-point meaningful perspective.

5. Meaningful dramatic perspective

The two states of skyscraper and bird's eye are exaggerated states of classical perspective that are very popular. They are in fact the same as the generalization of the two-point perspective to three-point one. In this state, there are two meaningful vanishing points on a meaningful horizon line (like the two-point meaningful perspective rules), and depending on whether the third vanishing point is in the upper or lower part of our horizon line, one of the states of skyscraper and bird's eye will be formed, respectively. In these two states, the third meaningful vanishing point is used to guide the vertical meaningful lines of the shape. In Fig.24, we have plotted a cube in the state of skyscraper meaningful perspective, the fuzzification phase of which is shown in Fig.25. With shape 26, it is seen that skyscraper perspective in a definitive state is just one of the possible states for the meaningful shape 25, in which the artist chooses this state or state 24 from all possible meanings.

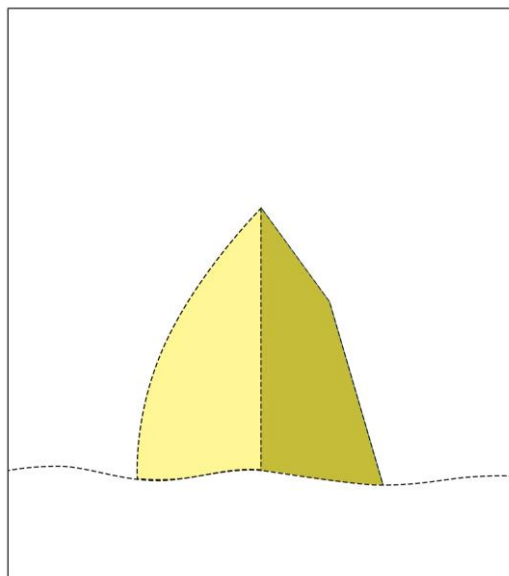

Fig.24. Defuzzificated mode of Fig25.

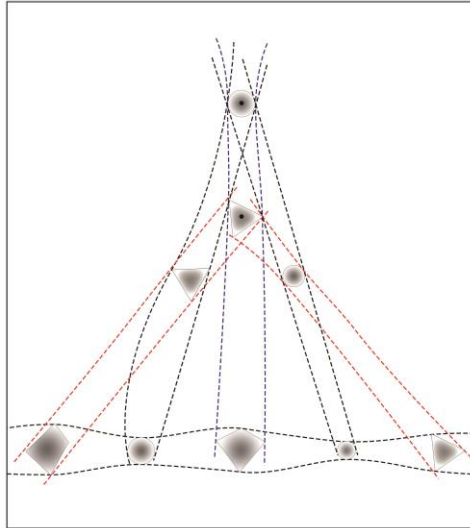

Fig.25. Fuzzificated mode of a cube in skyscraper meaningful perspective.

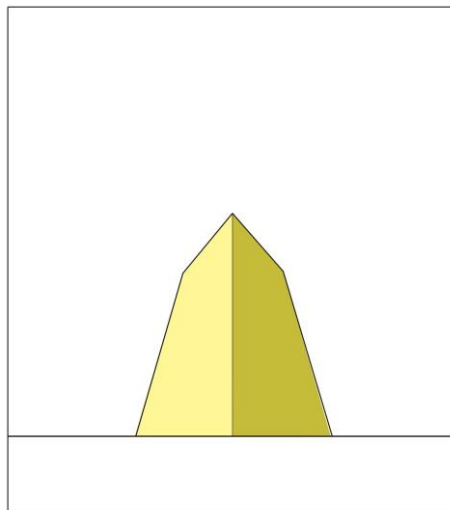

Fig.26. Cube in classical skyscraper perspective .

6. A practical example

In this section, using meaningful perspective, we present our approach to deforming and exerting the artist's excitement on an object. We know that architecture is one of the most widely used fields in the application of the perspective rules. Here consider Fig.27 that represents a building with a classical perspective view. Now, we want to deform the building based on the mental-emotional actions of the artist using the method mentioned for meaningful perspective. In the first step, we develop the classical vanishing points of this building into two optional meaningful vanishing points, Fig.28.



Fig.27. Model for testing the meaningful perspective.

In the next step, we select six points of the building and pass our meaningful lines through them – fuzzification step (these lines are such that they have the initial perspective in the classical lines), and among them, we select lines with a degree of meaning function that satisfies the mental tendencies of the artist creating the work (defuzzification step) to obtain the lines shown in Figure .28.

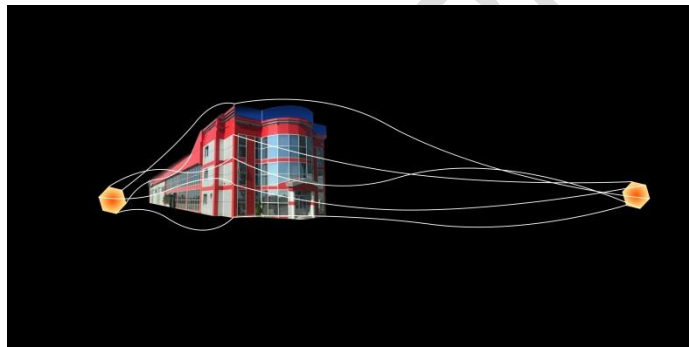

Fig.28. defuzzification step of Fig.27.

At this step, we connect the points on each of the classical perspective lines to the perspective curves of the shape resulted from the corresponding defuzzification step, so that the base shape in the meaningful perspective form can be obtained. These steps can be seen in Fig.29.



Fig.29. Final mode of meaningful perspective.

Conclusion

In this paper, in response to the problem of artificiality of the classical perspective, we develop a meaningful development of perspective rules based on the rules of fuzzy geometry. In such a way that the works produced maintains individuality and the behavioral-emotional actions of each artist while they are regular. The advantages of our definitions in this article are that they a) include the rules of classical perspective (in its definitive state); b) are simple and understandable; c) are flexible and expandable to finite choices. It should be noted that the purpose of this article is to provide geometric rules and methods for artists and they do not discuss the analysis and critique of artistic works. Obviously, the topic of critique of the artistic works in terms of meaningful perspective is of the future works and researches. It should be noted that one of the side results of this article is achieving a regular Kantian principle of individuality for deformation in art which can be useful in creating work as well as criticizing or producing teaching methods. This is the subject of future research and articles.

References

- [1]Mante H, La composition photographie ; 1977 .
- [2]Halimi M, Basic design,Tenth Edition;2013.
- [3]Gomberich E.H, The story of art; 1995.
- [4]Gardner H, Gardner's Art through the Ages;2009.
- [5]VaziriMoghaddam M, Drawing for graphics students; 2003.
- [6] Asasian M, Meaningful forms and fuzzy Geometry I:MPB&MGP, Asian research journal of mathematics; 2018.
- [7] Asasian M, Meaningful forms and fuzzy Geometry II: Meaningful surface & Meaningfully flat criterion, Asian research journal of mathematics; 2018.
- [8] Asasian M, An introduction to Expressionism analysis based on meaningful deformation, Current journal of Applied science and technology;2018.
- [9] Asasian M, Contour classification in drawing based on fuzzy thinking, Asian research journal of mathematics; 2018.
- [10] Wolchonok L, The Art of Pictorial Composition;1961.
- [11]Creco S, The art of perspective drawing;1968.