

Design and Implementation of an Electric Cooker Control System as a Means of Preventing Domestic Fire Incidence.

Akinwole OO

Department of Electrical/Electronic Engineering,
Federal Polytechnic, Ado – Ekiti, Nigeria
oyeakin2003@yahoo.com,

Abstract

Open loop control system is the type without feedback, that is, no sensor sensing the control variable, hence works on time basis. The paper established the facts that the system will prevent ubiquitous fire incidences associated with electric stoves and other heating devices. It describes the application of simple electronics circuitries in designing the low cost Cooker Control Device. The building blocks of the unit were designed one after the other using preferred components available in the local markets. The project was wired on Breadboard. The board permits the design to be tested without employing soldering processes. The design enumerates some important construction precautions which are further accentuated with the inclusion of various tips on healthy soldering processes. It is believed that the unit will prevent fire incidences associated with electric cooker. Simple explanations given to drive home power electronics principles used and copious illustrations rendered will make the innovative and ingenious enterprise interesting to power electronics enthusiasts and other professionals alike. The paper recommends incorporation of embedded system with Liquid Crystal Display in the future design improvement.

Keywords: Astable, Electric Cooker, Control, Monostable, Transistor Switch,

Introduction.

Power Electronics engineers make use of knowledge of Science to design machines and appliances in order to solve problems of mankind. In-depth knowledge of power electronics has assisted power engineers at a larger scale. This development has dovetailed into more enrolment of students wanting to pursue electronics related courses in the Universities and Polytechnics worldwide.

These innovations comprise control systems that tend to enable the equipment to operate in an automatic fashion hence a feedback control system. Also, so many control systems are open loop, that is, they do not have feedback paths. They are being referred to as open loop control systems. They are time based; there are no sensors to sense the controlled variables for comparing with the desired input settings [1]. Most of the times, this is as a result of the type of task the machine is designed for. For example, washing machines, there is a problem

of unavailability of a transducer that can measure the cleanliness of the clothing hence they are controlled on time basis. Usually domestic fire outbreaks are related to electric cookers or boiling rings. It happens especially when the user forget to switch off the cooker after a power failure; and when it is restored, no one is around. It can also be as a result of forgetting the food on the cooker over a long period of time. In both cases, the food is burnt off, the pot becomes deformed and afterward, occurrences of fire do ensue. But with Cooker control unit, the user selects a predetermined time that the control unit will supply power to the terminals of the cooker. It depends on the type of the food to be cooked. The control unit counts the time and at its expiration disengage the Cooker from the power supply. If there is need, the user can reengage the unit by pressing start button on the control unit. The Cooker Control Unit incorporates a buzzer unit which produces a pulsed tone to inform the user about an expiration of a timing cycle.

Methodology

A simple block diagram was fashioned based on the requirements and the expected tasks from the Control unit, Figure 1. Each building block was implemented by deploying simple electronics circuitries. The system hovers around a timer unit which incorporates RC networks for the determination of timing cycles. Since calculated values of capacitors are hardly obtained, a convenient Capacitance value was selected while Resistor values varied. By using a solid tantalum capacitor ensures the accuracy of the timing cycle since they parade high leakage resistance and they usually have bigger capacitance per little space they occupy [2]. Pulsed tone generator was realized using NOR gates connected as Astable multivibrator. Sizes of wiring conductors were selected based on the power rating of the unit and current flowing in each stage of its stages.

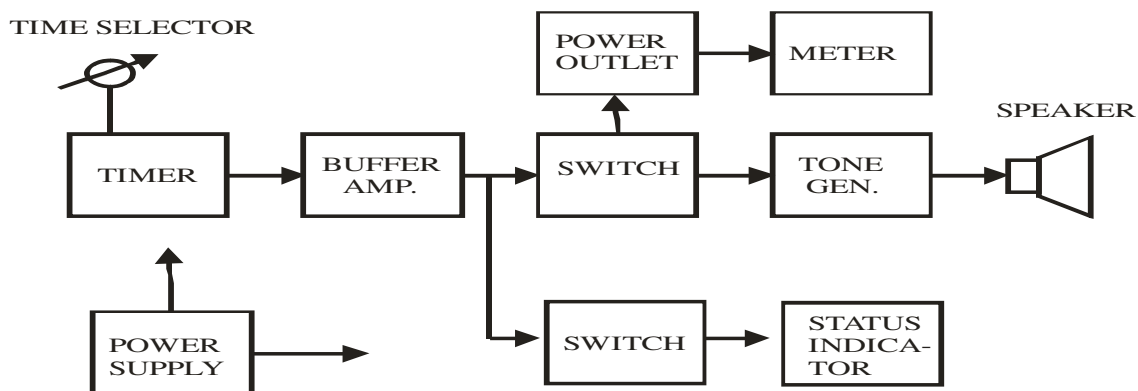

Figure 1: Block Diagram of the Cooker Control Unit

Design of a Timer Unit Using 555 Integrated Circuit.

Using the 555 Timer in Monostable circuit configuration, [3] Figure 2, one can achieve needed delay time T_d . The supply voltage $V_{cc} = 12V$, while low and high output voltages are 0.25V and 10V respectively.

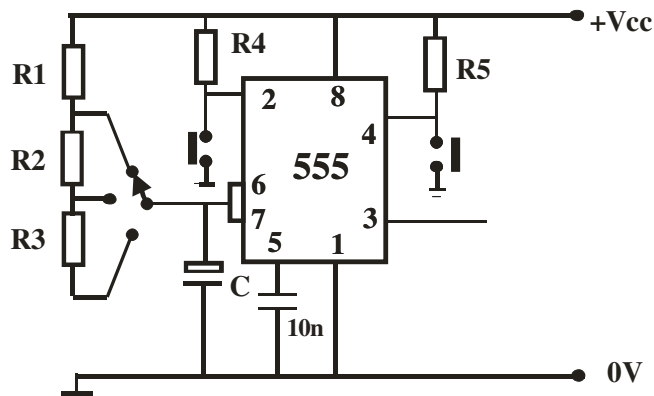

Figure 2: The Timer Showing Timing Resistors

$$T_d = 1.1RC$$

For 5 minutes Time delay, taking Capacitor $C = 94\mu F$, Resistor R value can be calculated.

$$R_5 = \frac{T_d}{1.1 C} = \frac{300}{1.1 \times 94 \times E^{-6}} = 2.9M\Omega$$

Preferred value = 3.0M Ω

Likewise for 30minutes time delay,

$$R_{30} = \frac{T_d}{1.1 C} = \frac{1800}{1.1 \times 94 \times E^{-6}} = 17.4M\Omega$$

Also calculating for 60 minutes time delay,

$$R_{60} = \frac{T_d}{1.1 C} = \frac{3600}{1.1 \times 94 \times E^{-6}} = 34.8M\Omega$$

As this configuration would be used, Resistors values R2 and R3 can be calculated thus.

$$R_2 = 17.4 M\Omega - 2.9 M\Omega = 14.5 M\Omega \text{ (Preferred Value = } 15M\Omega)$$

$$R_3 = 34.8 M\Omega - 17.4 M\Omega = 17.4 M\Omega \text{ (Preferred Value = } 18M\Omega)$$

Design of a Buffer Amplifier

A buffer amplifier in figure 3 presents high input impedance to the output of Timer in order to avoid loading it [4]. It also present low output impedance to the next stage. A common

collector amplifier configuration was adopted which fits- in into the requirement. Its gain is 1 [5].

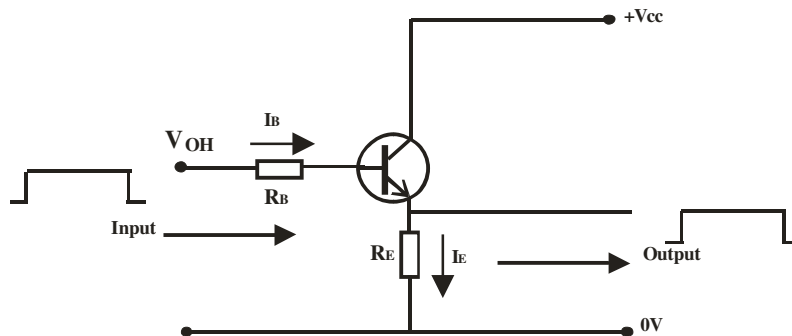

Figure 3: A Common Collector Amplifier Serving as a Buffer

By using a switching and linear amplification transistor 2N2222 in this design, where $h_{FE \min} = 100$ [6]

Let $V_E = 0.5 \times V_{cc}$

That is, $V_E = 6V$

$V_{BE} = 0.7V$

$V_B = V_E + V_{BE}$

$= (6 + 0.7) V = 6.7V$

Taking $H_{FE} = 100$, $I_C \approx I_E = 50mA$

But $I_B = I_C / H_{FE} = 50mA/100 = 0.5mA$

$R_B = (V_{OH} - V_B) / I_B$

$R_B = R6 = (10 - 6.7)V / 0.5mA = 6.6K\Omega$ (Preferred Value = $6.8K\Omega$)

$R_E = R7 = V_E / I_E = 6V / 50mA = 120\Omega$

Design of a Relay Switch

During the timing cycle the input signal is high. The high input is inverted by the Common Emitter Amplifier having a relay coil as the load. A low voltage at the collector of the amplifier present $+V_{cc}$ across the relay coil thereby activating the contact sets. The normally open contact closes while the normally close contact opens; figure 4.

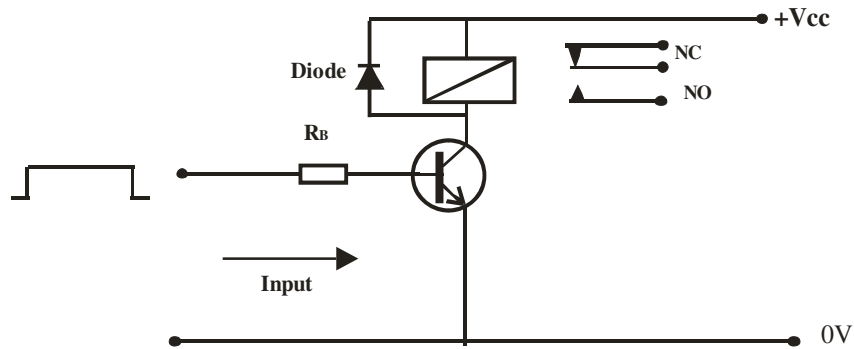

Figure 4: Common Emitter Amplifier with a Relay Load

$$V_{CC} = 12V$$

$$H_{FE} = I_C / I_B$$

$$\text{Relay Coil Resistance} = 400\Omega$$

$$I_C = V_C / R_{\text{Relay}} = 12 / 400 = 30\text{mA}$$

$$H_{FE} = 100$$

$$\text{So } I_B = I_C / H_{FE} = 30\text{mA} / 100 = 0.3\text{mA}$$

For saturation, $I_B > 0.3\text{mA}$ [7]

$$\text{Let } I_B = 3\text{mA}$$

$$R_B = (V_{OH} - V_{BE}) / I_B$$

$$R_B = R_8 = R_9 = (10 - 0.7)V / 3\text{mA} = 3.1\text{K}\Omega \text{ (Preferred value} = 3\text{K}\Omega)$$

Design of a Pulsed Tone Generator

A pulsed tone generator provides a unique warning sound different from other sounds emanating from our environment perhaps from the mains hums or low frequency vibrations from vehicles. To achieve this sound, two astables are designed, one medium frequency stage being driven by a low frequency unit. That is, a medium frequency tone is being pulsed by a low frequency signal. Figure 5 shows a NOR gate astable configurations.

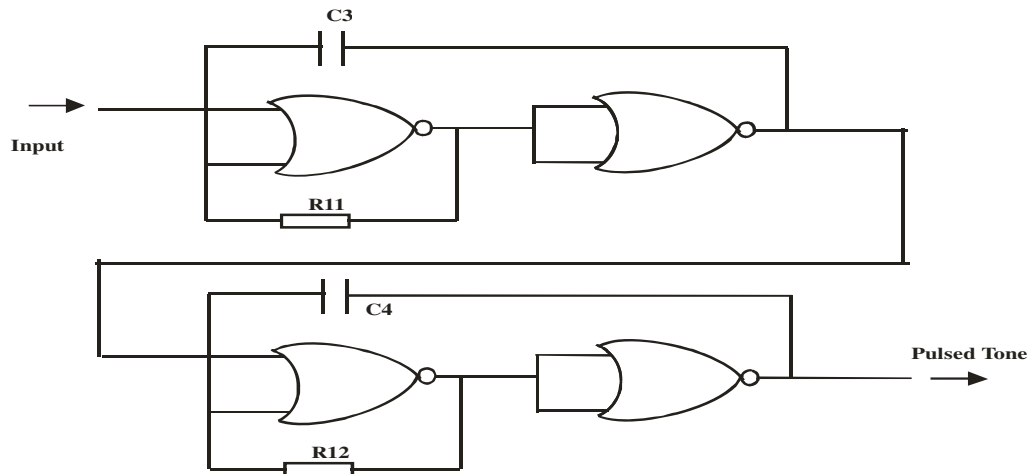

Figure 5: NOR Gates Configuration

Design of a 4Hz Astable

The oscillation frequency $f = \frac{1}{2.5 R C}$

Let C3 = 100nF

$$R11 = \frac{1}{2.5 f C3} = \frac{1}{2.5 \times 4 \times 100 \times 10^{-9}} = 1M\Omega$$

Design of a 600Hz Astable

The oscillation frequency $f = \frac{1}{2.5 R C}$

Let C4 = 10nF

$$R12 = \frac{1}{2.5 f C4} = \frac{1}{2.5 \times 600 \times 10 \times 10^{-9}} = 66.6K\Omega \text{ (Preferred value = 68K}\Omega\text{)}$$

Design of a +12V Regulated DC Power Supply Unit

Specification:

Voltage Output = +12V

Current Output = 0.5A

An integrated circuit voltage regulator 7812 was selected because it can furnish the required specification for the supply unit in figure 8, it has voltage output of 12V and current output of 1.0A [8]

The transformer for the unit is selected as follows:

Maximum dc input voltage for fixed IC regulator is $V_{dc}(\text{max})$ and is equal to 25V.

Also the minimum dc input voltage $V_{dc}(\text{min}) = V_{\text{output}} + V_{\text{drop across 7812}} = (12 + 5)V = 17V_{dc}$

$V_{ac}(\min) = \frac{V_{dc}(\min)}{\text{Voltage Conversion}} = \frac{17}{1.4} = 12.1V_{ac}$, that is, the minimum AC voltage from the transformer secondary winding. Nearest preferred Transformer value = 15V

If a 15V transformer is selected, it will provide $15 \times 1.4 V_{dc}$, that is, $21V_{dc}$ at the input terminals of the voltage regulator. This is still within minimum and maximum input rating for the regulator 7812, the value should be greater than or equal to 14.5V and less than or equal to 30V. ($14.5 \leq V_{dc} \leq 30$) [9]. Power dissipation within the regulator is $P_o = (V_{in,dc} - V_{output}) \times I_o$

$P_o = (21 - 12) V \times 0.5A = 4.5W$. The value is within the regulator's manufacturer's specification. VA rating for the transformer is $V_{ac} I_o = 15V \times 0.5A = 7.5VA$

Power diodes D3 to D6 were selected to have their V_{RRM} in excess of 15V and 0.5A. 1N5401 were used, they have Maximum Mean Forward Current and Maximum Repetitive Reverse Voltage equal to 3A and 50V respectively. Selecting diodes with high current rating will ensure that those diodes are not overheated. A typical high capacitance ($2000\mu F$) smoothing capacitor was selected but ensured that the voltage rating is above $2 \times 21V$. Hence, a preferred value of 50V was selected. C6 and C7 are $0.1\mu F$ capacitors while C8 is a polarised $1\mu F$ low leakage type. These are values suggested by voltage 7812 application manuals which will help in achieving good results from the component. Red LED D7 with forward current $I_f = 25mA$ require $V_d = 1.7V$ and current limiting resistor of $\frac{12V - 1.7V}{25mA} = 412$ Ohms. A preferred value of 580Ω to $1k\Omega$ will suffice.

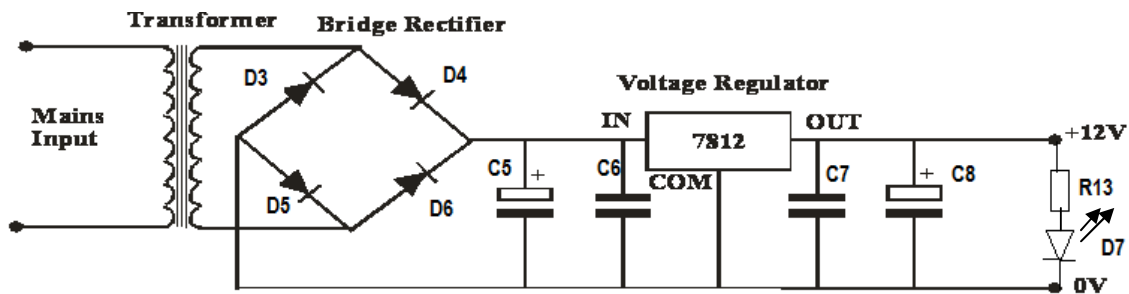

Figure 8: Power Supply Unit

Breadboarding and Construction

Breadboard, also being referred to as protoboard was used to carry out tests on the components. Also circuit stages were wired on it from where working circuits are transferred

on the veroboard for permanent connection through soldering processes. In order to ensure high reliability and low failure, the following precautions were adhered to.

- All soldered joints had bright shiny appearance and void of surface flux.
- All soldered joints were free of holes, scars or spikes.
- Soldered joints had good fillet between conductor and terminals.[2]

For the success of this project, it was ensured that all components were mounted properly on the veroboard, and were of the correct types, values, mounted in the correct manner and all at correct positions. It was also ensured that:

- Components leads were not bent at the point of exit from the component. The gap between each component and the bend was at least 1.5mm.
- Leads were not formed too sharply. The radius of bends was at least equal to the diameter of the leads.
- Bends were symmetrically positioned with respect to components.
- Leads were formed to align with fixing holes on the board.
- Small resistors and capacitors were mounted flush with the board.
- Components mounted vertically were seated on the board.
- IC sockets were employed for easy maintainability.

Packaging

The design of the casing was done to match any other household equipment. It is cubical in shape with dimensions of 130mm × 270mm × 200mm and made from metal sheets of 1mm gauge. Drawings of different views are shown in figures below.

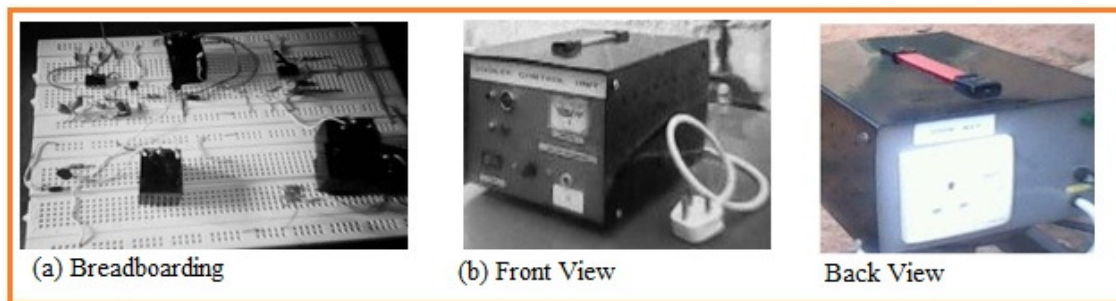

Figure 9: The Cooker Control Unit showing Components Wiring on Breadboard and its Completed Front and Back View

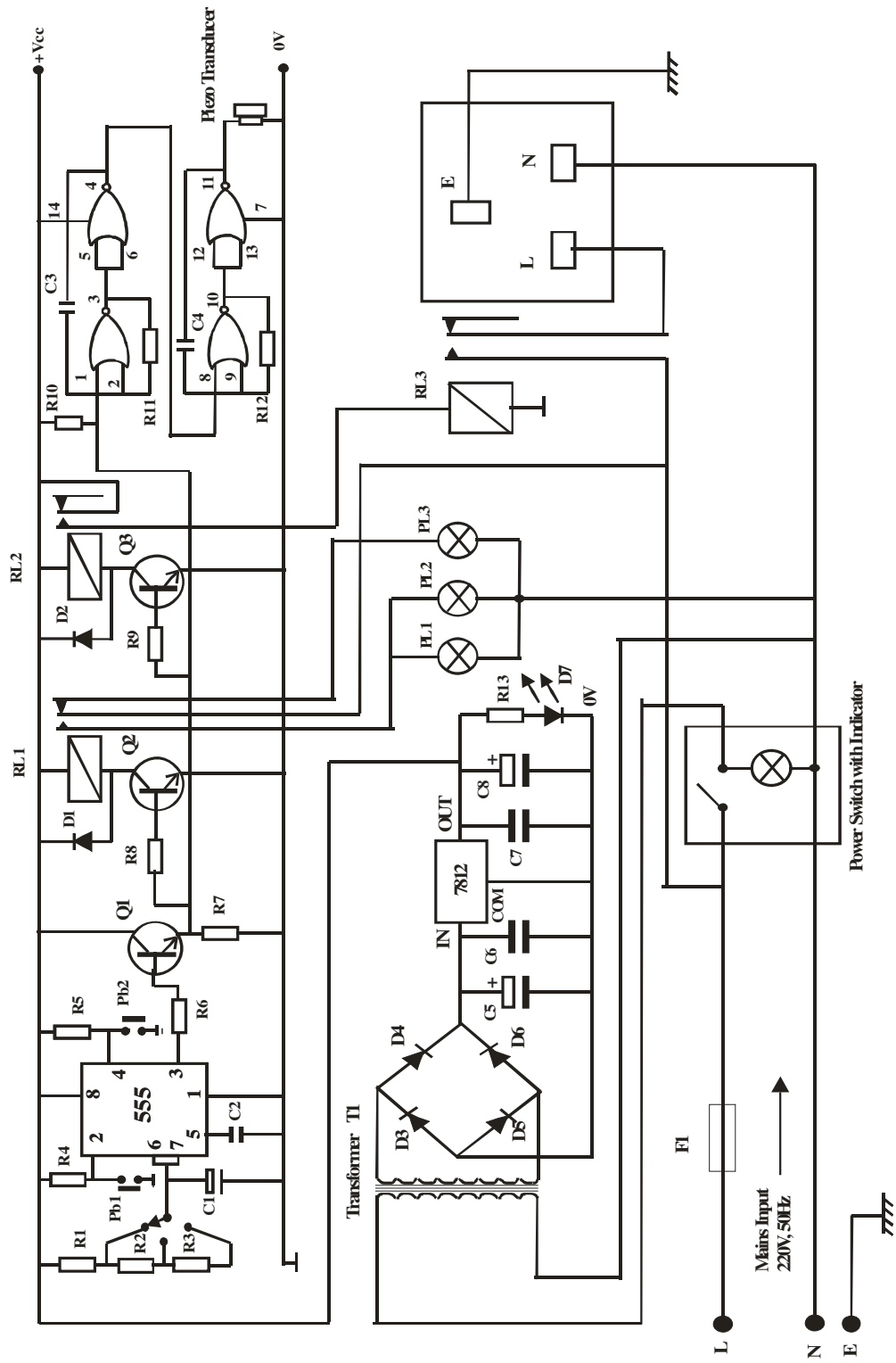

Figure 10: Circuit Diagram of the Complete System

Table 1: Components Types and Values

S/N	Components	Values
1	R1	3 M Ω
2	R2	15 M Ω
3	R3	18 M Ω
4	R4	10 K Ω
5	R5	10 K Ω
6	R6	6.8 K Ω
7	R7	120 Ω
8	R8 - R10	3 K Ω
9	R11	1 M Ω
10	R12	68 K Ω
11	R13	1 K Ω
12	C1	94 μ F (Tantalum)
13	C2	10nF
14	C3	100nF
15	C4	10nF
16	C5	2000 μ F , 50V
17	C6	0.1 μ F
18	C7	0.1 μ F
19	C8	1 μ F
20	D1 - D6	1N4001
21	D7	LED, 25mA, Red
22	Q1-Q3	2N2222
23	IC1	LM555
24	IC2	CD4001
25	IC3	LM7812
26	RL1-RL2	12V, 400 Ω , 7A
27	RL3	12V,150 Ω , 20A
28	PL1-PL2	220V, Green
29	PL3	220V, Red
30	Panel AC Meter Switch with	1nos
31	Indicator	1nos
32	Fuse Holder	1nos
33	Fuse	8A
34	Socket Outlet	13A
35	3Core Cable	2.5mm Sq CSA
36	Veroboard	2Nos

Results and Discussion

The Cooker Control Unit, figure 9, has its first stage as a time delay circuit using 555 Timer Integrated Circuit. It comprises a rotary switch which selects the time delays.

A negative going pulse is applied to pin 2 through a make-break pushbutton while pin 4 is used to reset the timing cycle. The output of the stage is taken from pin 3. The timer unit drives a Common collector Amplifier (Emitter Follower) circuit which serves as a buffer unit. It presents high impedance to the timer unit while presenting low impedance to the next stage. In other words, it prevents the loading of the high output of the timer stage. Common Collector stage has a gain approximately equal to unity with zero degree phase shift since the output is derived from the emitter lead of the transistor [8].

The buffer stage is employed to drive two Common Emitter Amplifier stages having relay coils as their loads. Common Emitter stages furnish 180° phase shifts and are referred to inverter stages. So the high output from the timer which was obtainable also at the emitter of the buffer stage is inverted for each timing cycle thus presenting low voltage ($\approx 0.25V$) at the collector of the common emitter stages which effectively applied 12V across their relay coils at Q2 and Q3 Collectors. During each timing cycle, Relay RL1 applies 220V across pilot lamps PL1 and PL2 which indicates that 220V AC is at the terminals of the cooker. This is achieved through its normally open contact set. Whenever a timing cycle elapses, RL1 de-energizes thus switching of the Green lamps and energizes PL3, a red lamp which signify that power has being removed from the cooker. Relay RL3 is activated through relay RL2 during each timing cycle figure 10. RL3 is a high power type and its normally open contact is used applied power to the socket outlet. Its contact set is capable of conducting up to 20A AC. The pulsed tone oscillator unit is made from CMOS integrated circuit CD4001. This Dual-in-line Integrated Circuit (IC) comprises four units of NOR gates. Two NOR gates were wired as an astable oscillator with oscillating frequency of 600Hz while the remaining two were

connected as another astable but with 4Hz oscillating frequency. The low frequency stage of 4Hz was primed to drive 600Hz stage. The 600Hz medium frequency is being pulsed by 4Hz signal. The stage is an active low type. Input pin 2 was tied to Vcc through R10. The power supply unit was built around an IC regulator LM7812. It furnishes 12V at 1A [8,9].

Conclusion and Recommendations

The control unit was designed bearing in mind the environment in which it would be used. Its casing was painted with metallic black colour while the front and back faces were coated with grey colour. All components used for this prototype were sourced from the local market. It is believed that this will go in long way to enhance its maintainability. The following recommendations are hereby proffered:

- The system's reliability will be enhanced when it is used in a well ventilated environment.
- On no account should water or moisture be allowed into the unit.
- This Cooker Control Unit must be securely placed with no risk of falling.
- It is required that the equipment be powered from 220V, 50Hz [10].
- To further guarantee its reliability, the cooker to be powered by it should not exceed 1500W. In case of fault, the user should refer the system to a qualified electrical and electronics technician.
- Further study should be done in the area of improving electrical energy efficiency and incorporation of an embedded system, that is, usage of an Arduino microcontroller for the timing and other machine intelligence with Liquid Crystal display [11, 12].

References

- [1] Dorf, R.C. and Bishop, R. H (2001): Modern Control System. Prentice Hall
- [2] Akinwole, O.O. (2002): Practical Electronics. Mayfest Publication, Ado-Ekiti
- [3] Fairchild Semiconductors (2002): LM555 Single Timer. Components Data Sheets. Retrieved August, 2014 from www.alldatasheet.com
- [4] Crecraft, D., Gorham, D. and Loxton, R. (1999): Transistor and Basic Circuits. The Open University.
- [5] Theraja, B.L. and Theraja A.K.(2005): A Textbook of Electrical Technology. Chand and Company Limited.
- [6] Phillips Semiconductor Datasheets for Switching Transistor 2N2222. www.semiconductors.phillips.com
- [7] Electronics Hub. Transistor as Switch. Retrieved September, 2018 from www.electronicshub.org/transistor-as-switch/
- [8] Horowitz, P. and Hill, W. (2002). The Art of Electronics, Second Edition. Cambridge University Press
- [9]. CDIL LM7812 3- Terminal Positive Voltage Regulator Datasheets. Retrived online 2019 from www.datasheet.octopart.com/LM7812
- [10] Akinwole, OO. and Oladimeji TT(2017). Elements of Generator Selection, Sizing, and Maintenance in Nigerian Industries. International Journal of Advance Research and Innovation. Vol.5 Issue 2. pp276-278
- [11] Akinwole, OO, Oladimeji, TT. (2018). Design and Implementation of Arduino Microcontroller Based Automatic Lighting Control with I2C LCD Display. J. Electr Electron Syst 7:258
- [12] Akinwole, OO.(2015). Improving of Electrical Energy Efficiency in Nigerian Industries. International Journal of Computer Science Trends and Technology. Vol.3. Issue 3.pp170-176